

YOKE®

2020

Safety is our first priority™



Safety Components For Fall Protection



Worldwide Quality Type Approval And Certificate :

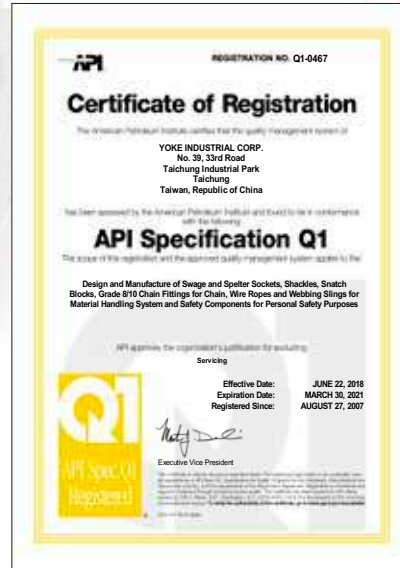
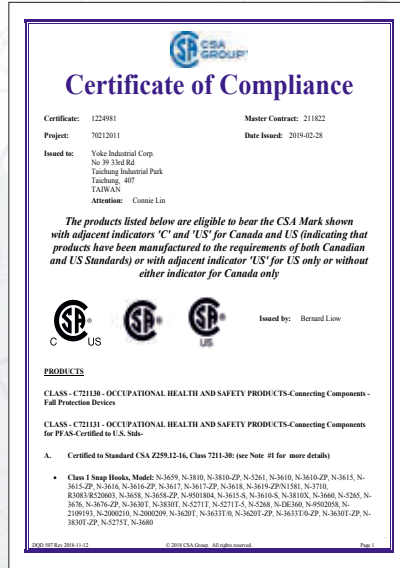
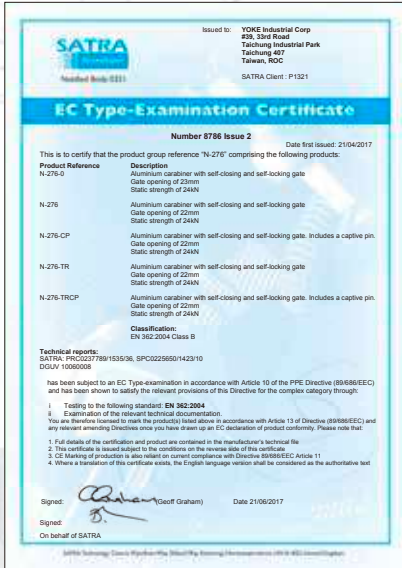

Rope Snaps
Rebar Hooks



D Rings
Buckles
Adjusters



Dielectric
Components



Aluminum alloy
& Stainless Steel
Components

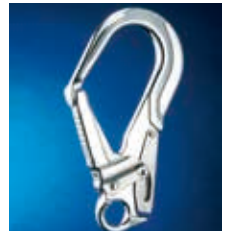

Steel &
Aluminum alloy
Carabiners

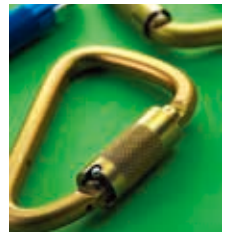

Rope Grabs



Miscellaneous

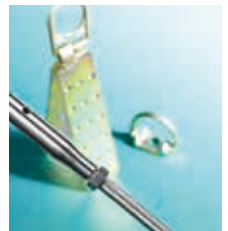

Safety is our first priority™
- Quality, Reliability, Innovation -



Strict Manufacturing, Quality Control, and Testing



YOKE operates a consistent production facility with quality control at every manufacturing stage. From raw materials to the completed product, YOKE's quality meets or exceeds ANSI, CSA and EN specifications.

YOKE is an ISO 9001 certified company and has Type Approval and audit program with CSA Group Testing & Certification Inc. (Canada) and SATRA Technology Centre Ltd. (England).

Test Certificates are included with every shipment from YOKE. These certificates are your assurance of unsurpassed quality.

- **Spectrographic Analysis :**
Ensure proper metallurgy content of all raw materials.
- **Proof Load Testing :**
All safety harness connecting components are 100% proof loaded to 3600 lbs / 16 kN.
- **Ultimate Breaking Load Test :**
Connecting and adjusting components are batch tested for ultimate breaking strength.
- connecting components - exceed 5000 lbs
- adjusting components - exceed 4000 lbs

Certificate of Conformance

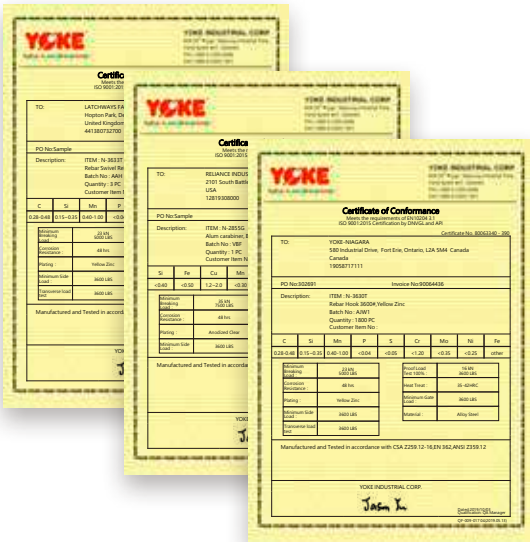

Year of manufacture & batch code links to Certificate of Conformance

Forged
PT: proof load tested

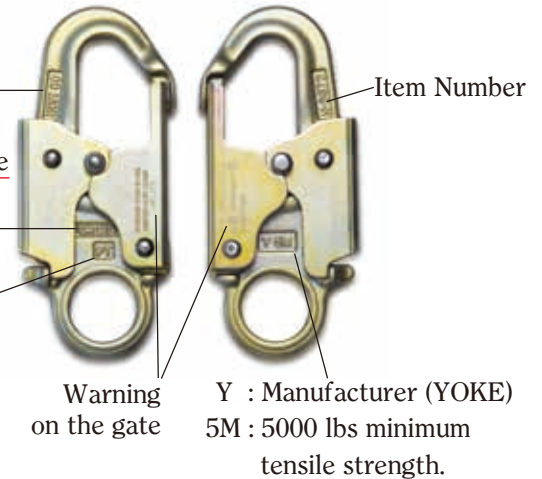

WARNING
YOKE HARDWARE IN THIS CATALOGUE IS DESIGNED FOR PERSONAL FALL PROTECTION AND IS NOT TO BE USED FOR MATERIAL HANDLING



COMPLETE RANGE OF ANSI/CSA CONNECTORS

The ANSI/CSA standard requires connectors with an integral eye to have gate strength (side and face) of 3600 lbs.

It also requires connectors without an integral eye to have all around gate strength of 3600 lbs (side, face and minor axis).

YOKE offers a full range of these ANSI/CSA compliant connectors:

- Snap Hooks
- Swivel Hooks
- Clevis Snap Hooks
- Indicator Swivel Hooks
- Rebar Hooks
- Swivel Rebar Hooks
- Pole Strap Snap Hooks
- Aluminum Rebar Hooks
- Aluminum Snap Hooks

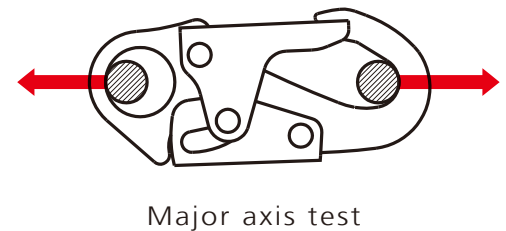
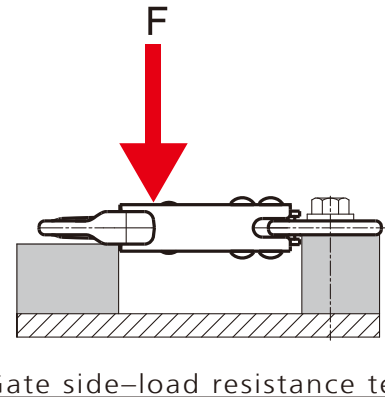
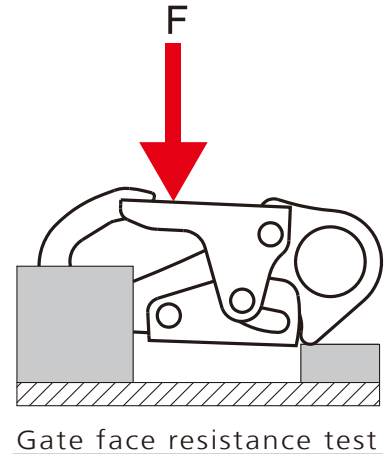

N-3610
Rope Snap Hook
3600 LBS gate strength

Forged steel, heat treated
 100% proof loaded to 3600 lbs / 16 kN
 Min. Breaking load : 5000 lbs / 23 kN

Meets :

- ANSI Z359.12-2019
- CSA Z259.12-16
- EN 362 : 2004

Net weight : 13.6 oz. / 388 g

Zinc Plated

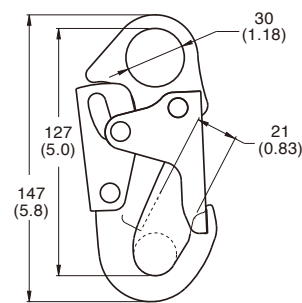

mm (inch)

N-3810
Stamped Rope Snap Hook
3600 LBS gate strength

Sheet steel, heat treated
 100% proof loaded to 3600 lbs / 16 kN
 Min. Breaking load : 5000 lbs / 23 kN

Meets :

- ANSI Z359.12-2019
- CSA Z259.12-16
- EN 362 : 2004

Net weight : 12.7 oz. / 362 g

Zinc Plated

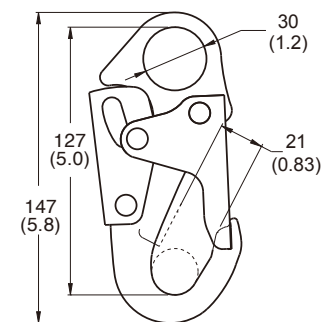

mm (inch)

N-3810X
Stamped Rope Snap Hook
3600 LBS gate strength

Sheet steel, heat treated
 100% proof loaded to 3600 lbs / 16 kN
 Min. Breaking load : 5000 lbs / 23 kN

Meets :

- ANSI Z359.12-2019
- CSA Z259.12-16
- EN 362 : 2004

Net weight : 10.6 oz. / 304 g

Zinc Plated

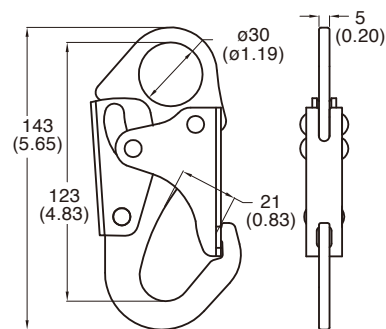

mm (inch)

N-3710
Rope Snap Hook
3600 LBS gate strength

Forged steel, heat treated
 100% proof loaded to 3600 lbs / 16 kN
 Min. Breaking load : 5000 lbs / 23 kN

Meets :

- ANSI Z359.12-2019
- CSA Z259.12-16
- EN 362 : 2004

Net weight : 11.7 oz. / 332 g

Zinc Plated

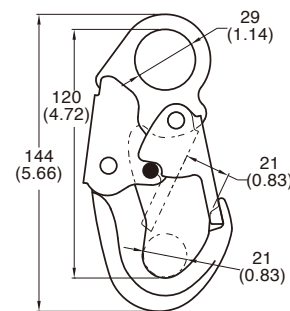

mm (inch)

N-3615
Indicator Swivel Hook
3600 LBS gate strength

Forged steel, heat treated
 100% proof loaded to 3600 lbs / 16 kN
 Min. Breaking load : 5000 lbs / 23 kN
 Meets :
 ● ANSI Z359.12-2019
 ● CSA Z259.12-16
 ● EN 362 : 2004
 Net weight : 17.5 oz. / 501 g
 Indicator Strength Options: ① 500 lbs ② 750 lbs
Zinc Plated

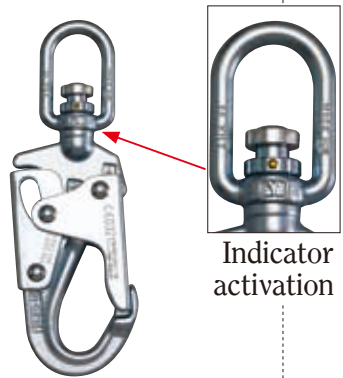

Indicator activation

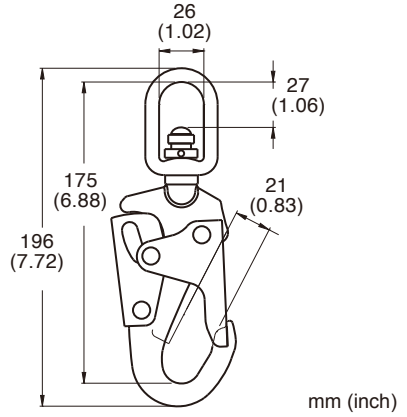

mm (inch)

N-3616
Swivel Hook
3600 LBS gate strength
(non-Indicator)

Forged steel, heat treated
 100% proof loaded to 3600 lbs / 16 kN
 Min. Breaking load : 5000 lbs / 23 kN
 Meets :
 ● ANSI Z359.12-2019
 ● CSA Z259.12-16
 ● EN 362 : 2004
 Net weight : 17.2 oz. / 490 g
Zinc plated

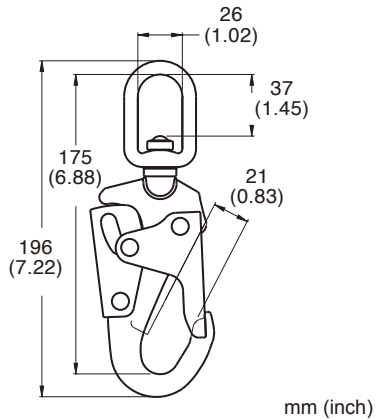

mm (inch)

N-3617
Clevis Snap Hook
3600 LBS gate strength

Forged steel, heat treated
 100% proof loaded to 3600 lbs / 16 kN
 Min. Breaking load : 5000 lbs / 23 kN
 Meets :
 ● ANSI Z359.12-2019
 ● CSA Z259.12-16
 ● EN 362 : 2004
 Net weight : 14.0 oz. / 398 g
Zinc Plated

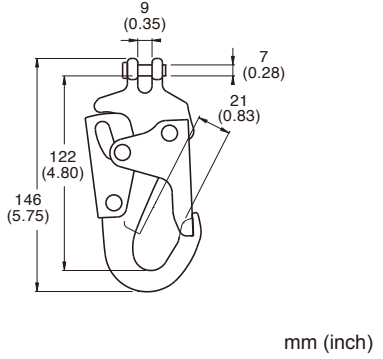

mm (inch)

N-3618
Tie Back Snap Hook
5000 LBS gate strength

Forged steel, heat treated
 100% proof loaded to 3600 lbs / 16 kN
 Min. Breaking load : 5000 lbs / 23 kN
 Meets :
 ● ANSI Z359.12-2019
 ● CSA Z259.12-16
 ● EN 362 : 2004
 Net weight : 16.0 oz. / 454 g.
Zinc Plated

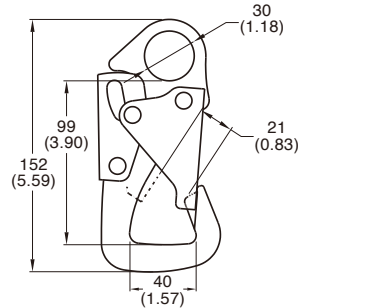

mm (inch)

N-3658
Pole Strap Snap Hook
3600 LBS gate strength

Forged steel, heat treated
 100% proof loaded to 3600 lbs / 16 kN
 Min. Breaking load : 5000 lbs / 23 kN

- Meets :
- ANSI Z359.12-2019
 - CSA Z259.12-16
 - EN 362 : 2004

Net weight : 17.8 oz. / 506 g

Zinc Plated

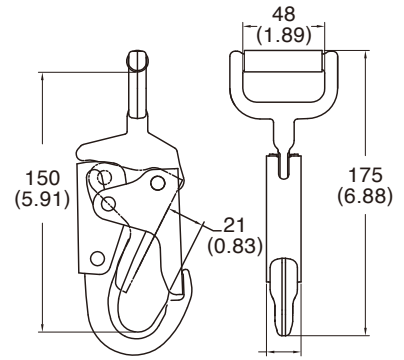

mm (inch)

N-3660
Spreader Snap Hook
3600 LBS gate strength

Forged steel, heat treated
 100% proof loaded to 3600 lbs / 16 kN
 Min. Breaking load : 5000 lbs / 23 kN

- Meets :
- ANSI Z359.12-2019
 - CSA Z259.12-16
 - EN 362 : 2004

Net weight : 25.4 oz. / 728 g

Zinc Plated

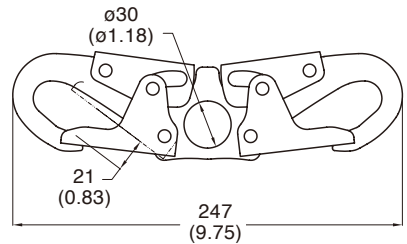

mm (inch)

N-RCT27337
Rebar Chain Assembly

Rebar Hook Gate Opening : 2.55 inch / 64.77 mm
 Snap Hook Gate Opening : 0.83 inch / 21.08 mm
 Length : 27inch / 685.8 mm
 Net weight : 74.1 oz. / 2.1 kg

New

Zinc Plated



**N-3032
Snap Hook**

Forged steel, heat treated
 Min. Breaking load : 5000 lbs / 23 kN
 Meets :
 ● EN 362 : 2004
 Net weight : 10.6 oz. / 303 g

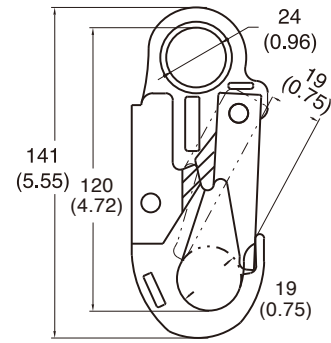
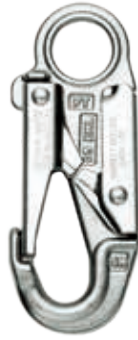

mm (inch)

Zinc Plated

**N-315
Stamped Snap Hook**

Sheet steel, heat treated
 Min. Breaking load : 5000 lbs / 23 kN
 Meets :
 ● EN 362 : 2004
 Net weight : 8.4 oz. / 239 g

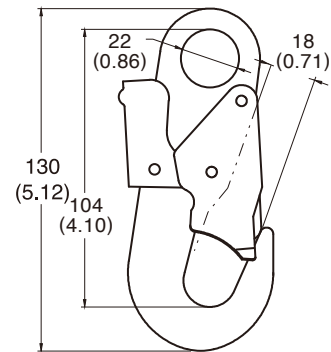

mm (inch)

Zinc Plated

**N-315X
Stamped Snap Hook**

Sheet steel, heat treated
 Min. Breaking load : 5000 lbs / 23 kN
 Meets :
 ● EN362 : 2004
 Net weight : 7.1 oz. / 200 g

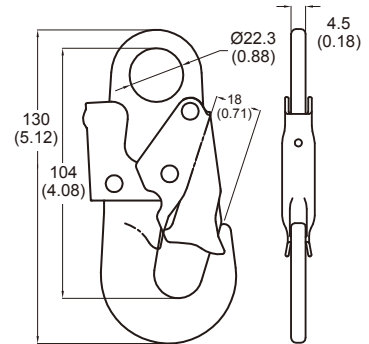

mm (inch)

Zinc Plated

**N-306
Stamped Snap Hook**

Sheet steel, heat treated
 Min. Breaking load : 5000 lbs / 23 kN
 Meets :
 ● EN 362 : 2004
 Net weight : 9.7 oz. / 275 g

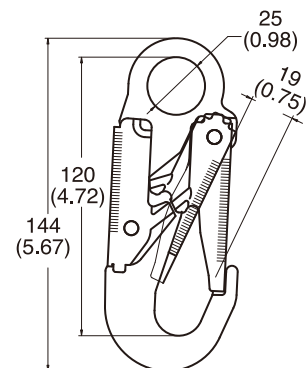

mm (inch)

Zinc Plated

**N-3035
Indicator Swivel Snap Hook**

Forged steel, heat treated
 Min. Breaking load : 5000 lbs / 23 kN
 Meets :
 ● EN 362 : 2004
 Net weight : 13.9 oz. / 394 g

Zinc Plated



Indicator activation

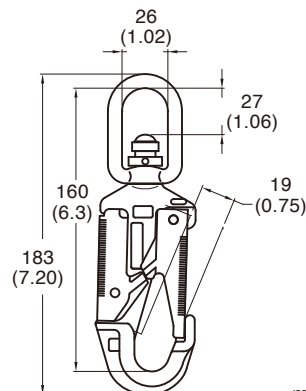

mm (inch)

**N-3035 / 0
Swivel Snap Hook**

Forged steel, heat treated
 Min. Breaking load : 5000 lbs / 23 kN
 Meets :
 ● EN 362 : 2004
 Net weight : 12.9 oz. / 366 g

Zinc Plated

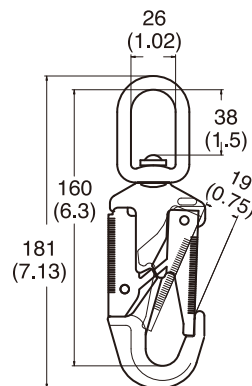

mm (inch)

**N-3167
Indicator Swivel Snap Hook**

Forged steel, heat treated
 Min. Breaking load : 5000 lbs / 23 kN
 Meets :
 ● EN 362 : 2004
 Net weight : 13.2 oz. / 377 g

Zinc Plated



Indicator activation

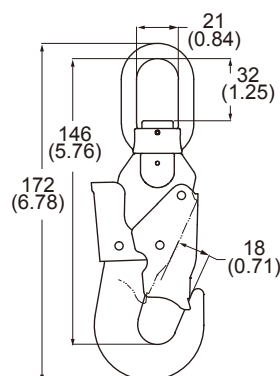

mm (inch)

**N-3167 / 0
Swivel Snap Hook
(non - Indicator)**

Forged steel, heat treated
 Min. Breaking load : 5000 lbs / 23 kN
 Meets :
 ● EN 362 : 2004
 Net weight : 12.9 oz. / 368 g

Zinc Plated

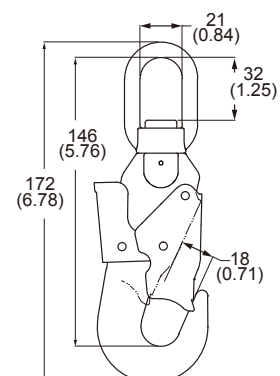

mm (inch)

**N-3033
Snap Hook**

Forged steel, heat treated
 Min. Breaking load : 5000 lbs / 23 kN
 Meets :
 ● EN 362 : 2004
 Net weight : 9.7 oz. / 276 g

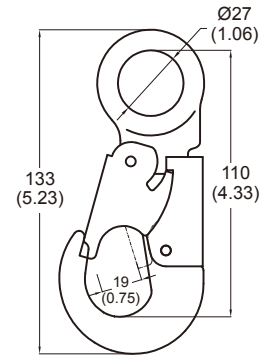

mm (inch)

Zinc Plated

**N-3056
Stamped Snap Hook**

Sheet steel, heat treated
 Min. Breaking load : 5000 lbs / 23 kN
 Meets :
 ● EN 362 : 2004
 Net weight : 9.0 oz. / 256 g

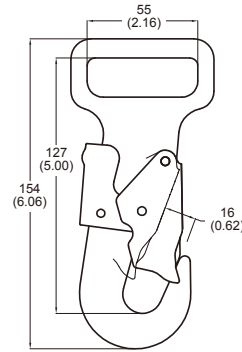

mm (inch)

Zinc Plated

**N-3039
Adjustable Slide Pole Hook**

Forged steel, heat treated
 Min. Breaking load : 5000 lbs / 23 kN
 Net weight : 6.0 oz. / 170 g

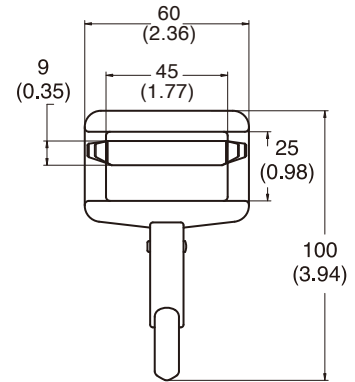

mm (inch)

Zinc Plated

**N-3040
Pole Strap Snap Hook**

Forged steel, heat treated
 Min. Breaking load : 5000 lbs / 23 kN
 Net weight : 4.1 oz. / 115 g

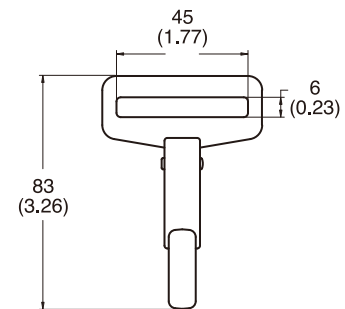

mm (inch)

Zinc Plated

N-3040-1
Pole Strap Snap Hook
With Wing Keeper

Forged steel, heat treated
 Min. Breaking load : 5000 lbs / 23 kN
 Net weight : 4.0 oz. / 115 g

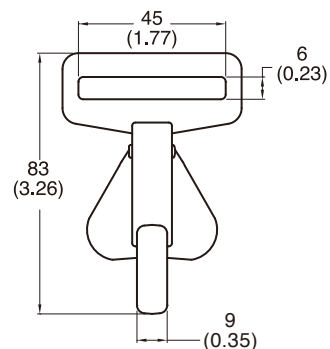

mm (inch)

Zinc Plated

N-3041
Pole Strap Snap Hook
With Wing Keeper

Forged steel, heat treated
 Min. Breaking load : 5000 lbs / 23 kN
 Net weight : 10.9 oz. / 310 g

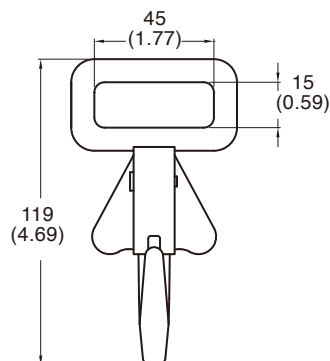

mm (inch)

Zinc Plated

N-3058
Pole Strap Snap Hook

Forged steel, heat treated
 Min. Breaking load : 5000 lbs / 23 kN
 Meets :
 ● EN 362 : 2004
 Net weight : 14.1 oz. / 396 g

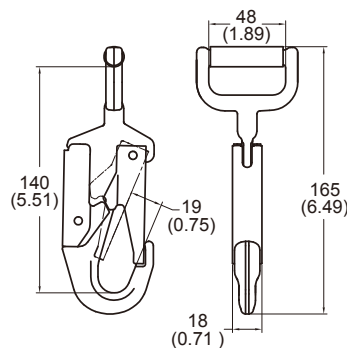

mm (inch)

Zinc Plated

N-3059
Pole Strap Snap Hook

Forged steel, heat treated
 Min. Breaking load : 5000 lbs / 23 kN
 Meets :
 ● EN 362 : 2004
 Net weight : 15.5 oz. / 454 g

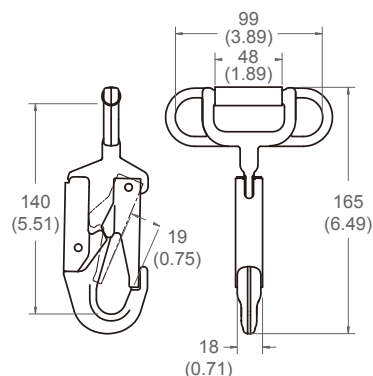

mm (inch)

Zinc Plated

**N-3049
Safety Pole Strap Snap**

Forged steel, heat treated
 Min. Breaking load : 5000 lbs / 23 kN
 Net weight : 11.4 oz. / 324 g

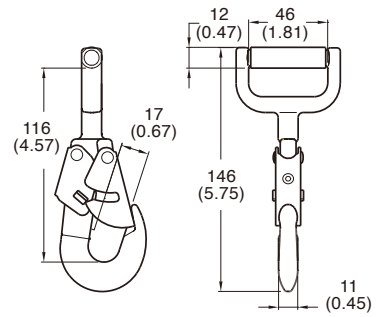

mm (inch)

Zinc Plated

**N-3036
Clevis Snap Hook**

Forged steel, heat treated
 Min. Breaking load : 5000 lbs / 23 kN
 Meets :
 ● EN 362 : 2004
 Net weight : 11.5 oz. / 328 g

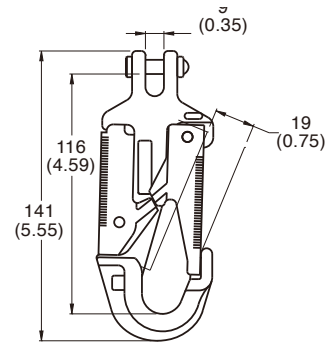

mm (inch)

Zinc Plated

**N-3155
Stamped Snap Hook**

Sheet steel, heat treated
 Min. Breaking load : 5000 lbs / 23 kN
 Meets :
 ● EN 362 : 2004
 Net weight : 8.8 oz. / 250 g

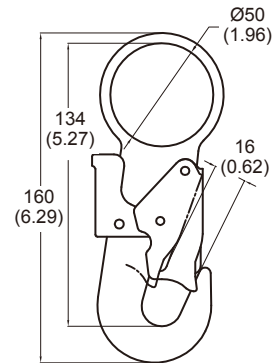

mm (inch)

Zinc Plated

**N-3161
Rope Snap Hook**

Forged steel, heat treated
 Min. Breaking load : 5000 lbs / 23 kN
 Meets :
 ● EN 362 : 2004
 Net weight : 9.4 oz. / 268 g

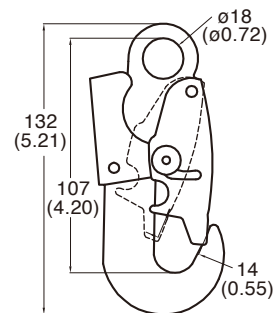

mm (inch)

Zinc Plated

N-3630T
Rebar Hook
3600 LBS gate / Transverse Load

Forged steel, heat treated
 100% proof loaded to 3600 lbs / 16 kN
 Min. Breaking load : 5000 lbs / 23 kN
 Meets :
 ● ANSI Z359.12-2019
 ● CSA Z259.12-16
 Net weight : 28.5 oz. / 800 g

Zinc Plated

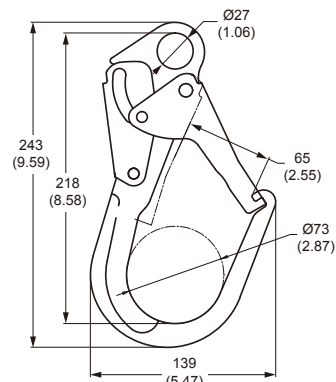

mm (inch)

N-3830T
Stamped Rebar Hook
3600 LBS gate / Transverse Load

Sheet steel, heat treated
 100% proof loaded to 3600 lbs / 16 kN
 Min. Breaking load : 5000 lbs / 23 kN
 Meets :
 ● ANSI Z359.12-2019
 ● CSA Z259.12-16
 Net weight : 26.3 oz. / 752 g

Zinc Plated

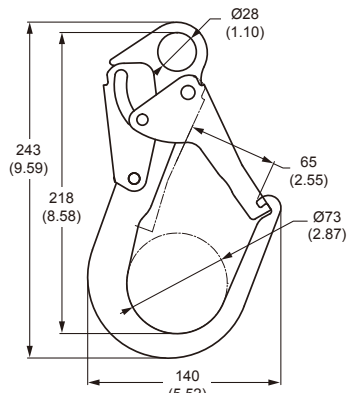

mm (inch)

N-3633T
Indicator Swivel Rebar Hook
3600 LBS gate / Transverse Load

Forged steel, heat treated
 100% proof loaded to 3600 lbs / 16kN
 Min. Breaking load : 5000 lbs / 23 kN
 Meets :
 ● ANSI Z359.12-2019
 ● CSA Z259.12-16
 ● EN 362 : 2004
 Net weight : 30.21 oz. / 823 g

Zinc Plated

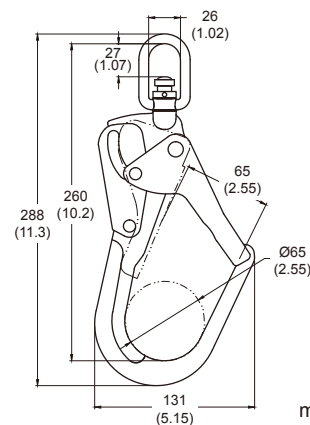
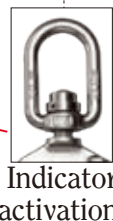

mm (inch)

N-3633T / 0
Swivel Rebar Hook
3600 LBS gate / Transverse Load

Forged steel, heat treated
 100% proof loaded to 3600 lbs / 16kN
 Min. Breaking load : 5000 lbs / 23 kN
 Meets :
 ● ANSI Z359.12-2019
 ● CSA Z259.12-16
 ● EN 362 : 2004
 Net weight : 30.21 oz. / 823 g

Zinc Plated

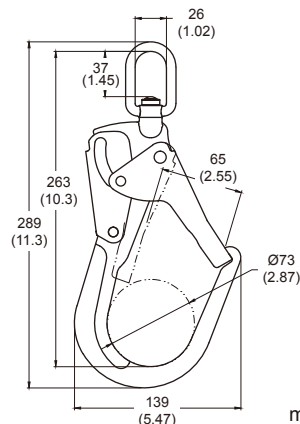

mm (inch)

N-3620T
Ladder Hook
3600 LBS gate / Transverse Load

Forged steel, heat treated
 100% proof loaded to 3600 lbs / 16 kN
 Min. Breaking load : 5000 lbs / 23 kN
 Meets :
 ● ANSI Z359.12-2019
 ● CSA Z259.12-16
 ● EN 362 : 2004
 Net weight : 17.99 oz. / 514 g
Zinc Plated

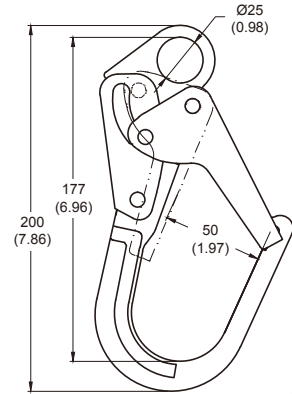

mm (inch)

N-3625T
Indicator Swivel Ladder Hook
3600 LBS gate / Transverse Load

Forged steel, heat treated
 100% proof loaded to 3600 lbs / 16 kN
 Min. Breaking load : 5000 lbs / 23 kN
 Meets :
 ● ANSI Z359.12-2019
 ● CSA Z259.12-16
 ● EN 362 : 2004
 Net weight : 22.5 oz. / 638 g
Zinc Plated



Indicator activation

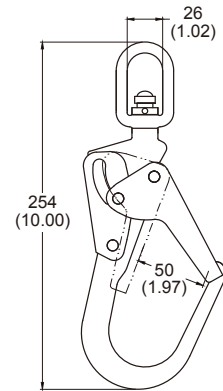

mm (inch)

New

N-3625T / 0
Swivel Ladder Hook
3600 LBS gate / Transverse Load

Forged steel, heat treated
 100% proof loaded to 3600 lbs / 16kN
 Min. Breaking load : 5000 lbs / 23 kN
 Meets :
 ● ANSI Z359.12-2019
 ● CSA Z259.12-16
 ● EN 362 : 2004
 Net weight : 22.86 oz. / 648 g
Zinc Plated

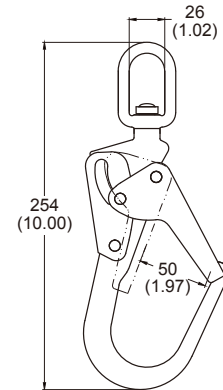

mm (inch)

New

N-3680
Rebar Hook
3600 LBS gate / Transverse Load

Sheet steel, heat treated
 100% proof loaded to 3600 lbs / 16 kN
 Min. Breaking load : 5000 lbs / 23 kN
 Meets :
 ● ANSI Z359.12-2019
 ● CSA Z259.12-16
 ● EN 362 : 2004
 Net weight : 34.7 oz. / 984g
Zinc Plated

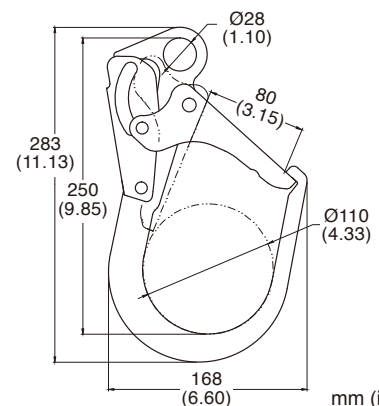

mm (inch)

New

**N-314-MX
Rebar Hook
Designed for 2" or small rebar**

Forged steel, heat treated
Min. Breaking load : 5000 lbs / 23 kN
Meets :
● EN 362 : 2004
Net weight : 17.6 oz. / 500 g

Part Number	Finish
N-314-ZP	Zinc plated, Polished
N-314-MX	Zinc plated, Matte
N-314-YW	Yellow Zinc plated, Matte

Zinc Plated

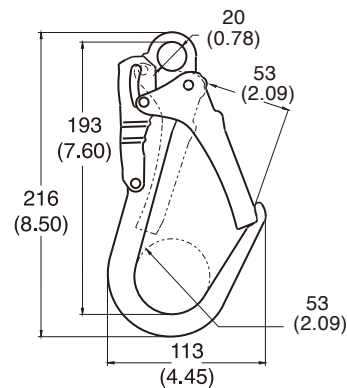

mm (inch)

**N-326
Rebar Hook
Designed for 2-1 / 4" rebar**

Forged steel, heat treated
Min. Breaking load : 5000 lbs / 23 kN
Meets :
● EN 362 : 2004
Net weight : 20.6 oz. / 594 g

Zinc Plated

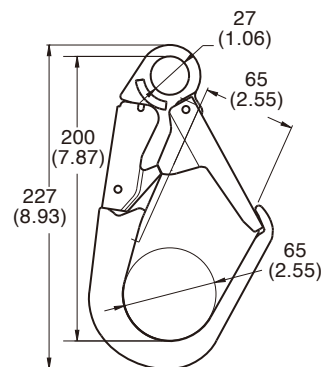

mm (inch)

**N-325 / 0
Swivel Rebar Hook
Designed for 2-1 / 4" rebar
(non-indicator)**

Forged steel, heat treated
Min. Breaking load : 5000 lbs / 23 kN
Meets :
● EN 362 : 2004
Net weight : 24.0 oz. / 680 g

Zinc Plated

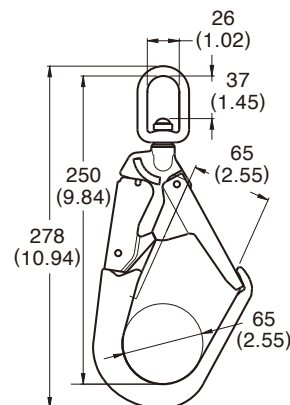

mm (inch)

**N-360
Large Capacity Rebar Hook**

Steel, heat treated
Min. breaking load : 5000 lbs / 23 kN
Meets :
● EN 362 : 2004
Net weight : 29.8 oz. / 846 g

Zinc Plated

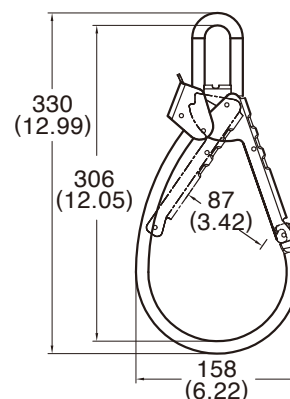

mm (inch)



**N-416L
D-Ring**

Forged steel, heat treated
 100% proof loaded to 3600 lbs / 16 kN
 Min. Breaking load : 5000 lbs / 23 kN
 Meets :
 ● ANSI Z359.12-2019
 ● CSA Z259.12-16
 Net weight : 4.2 oz. / 120 g

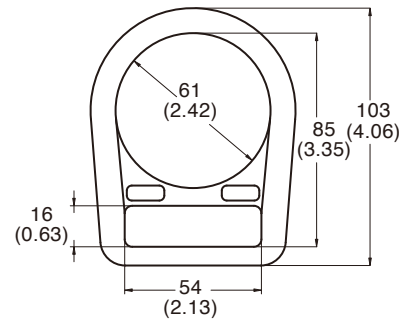

Zinc Plated

Light Weight Designed

mm (inch)

**N-416L-R
Roller D-Ring**

Forged steel, heat treated
 100% proof loaded to 3600 lbs / 16 kN
 Min. Breaking load : 5000 lbs / 23 kN
 Meets :
 ● ANSI Z359.12-2019
 ● CSA Z259.12-16
 Net weight : 4.3 oz. / 122 g

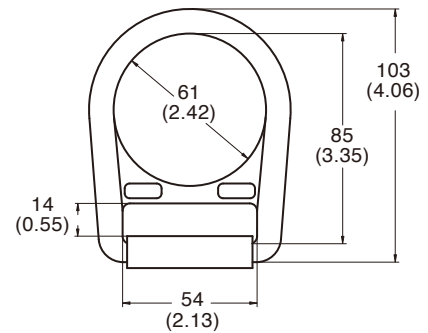

Zinc Plated

mm (inch)

**N-416
D-Ring**

Forged steel, heat treated
 100% proof loaded to 3600 lbs / 16 kN
 Min. Breaking load : 5000 lbs / 23 kN
 Meets :
 ● ANSI Z359.12-2019
 ● CSA Z259.12-16
 Net weight : 5.0 oz. / 142 g

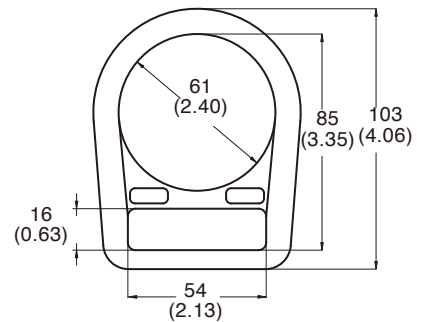

Zinc Plated

mm (inch)

**N-416R
Roller D-Ring**

Forged steel, heat treated
 100% proof loaded to 3600 lbs / 16 kN
 Min. Breaking load : 5000 lbs / 23 kN
 Meets :
 ● ANSI Z359.12-2019
 ● CSA Z259.12-16
 Net weight : 5.1 oz. / 146 g

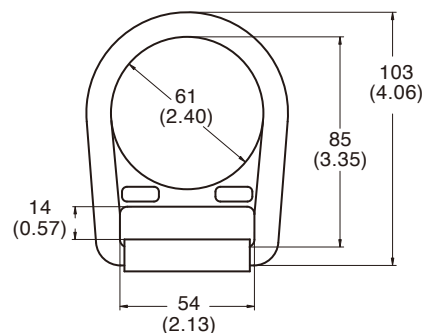

Zinc Plated

mm (inch)

**N-414
D-Ring**

Forged steel, heat treated
 100% proof loaded to 3600 lbs / 16 kN
 Min. Breaking load : 5000 lbs / 23 kN
 Meets :
 ● ANSI Z359.12-2019
 ● CSA Z259.12-16
 Net weight : 5.1 oz. / 145 g

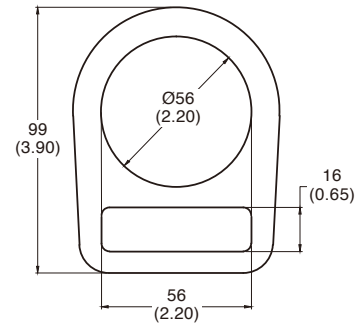

mm (inch)

Zinc Plated

**N-414X
D Ring**

Sheet steel, heat treated
 100% proof loaded to 3600 lbs / 16 kN
 Min. Breaking load : 5000 lbs / 23 kN
 Meets :
 ● ANSI Z359.12-2019
 ● CSA Z259.12-16
 Net weight : 4.1 oz. / 117 g

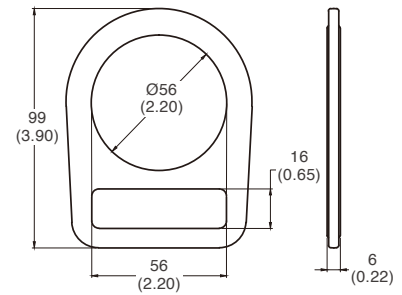

mm (inch)

Zinc Plated

New

**N-414R
Roller D-Ring**

Forged steel, heat treated
 100% proof loaded to 3600 lbs / 16 kN
 Min. Breaking load : 5000 lbs / 23 kN
 Meets :
 ● ANSI Z359.12-2019
 ● CSA Z259.12-16
 Net weight : 5.2 oz. / 149 g

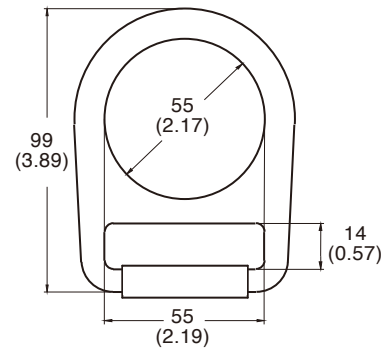

mm (inch)

Zinc Plated

**N-409
D-Ring**

Forged steel, heat treated
 100% proof loaded to 3600 lbs / 16 kN
 Min. Breaking load : 5000 lbs / 23 kN
 Meets :
 ● ANSI Z359.12-2019
 ● CSA Z259.12-16
 Net weight : 8.4 oz. / 228 g

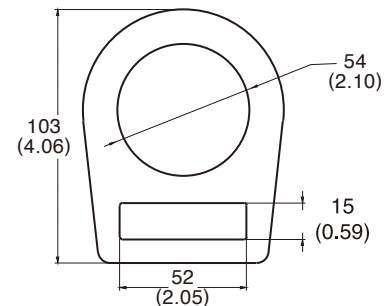

mm (inch)

Zinc Plated

**N-418
D-Ring**

Forged steel, heat treated
 100% proof loaded to 3600 lbs / 16 kN
 Min. Breaking load : 5000 lbs / 23 kN
 Meets :
 ● ANSI Z359.12-2019
 ● CSA Z259.12-16
 Net weight : 3.8 oz. / 112 g

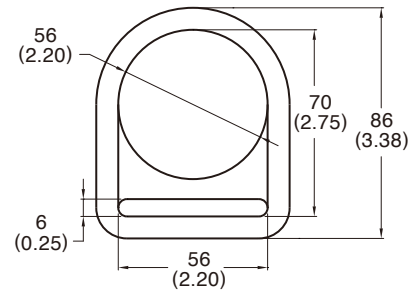

Zinc Plated

mm (inch)

**N-415
Stamped D-Ring**

Sheet steel, heat treated
 100% proof loaded to 3600 lbs / 16 kN
 Min. Breaking load : 5000 lbs / 23 kN
 Meets :
 ● ANSI Z359.12-2019
 ● CSA Z259.12-16
 Net weight : 5.0 oz. / 142 g

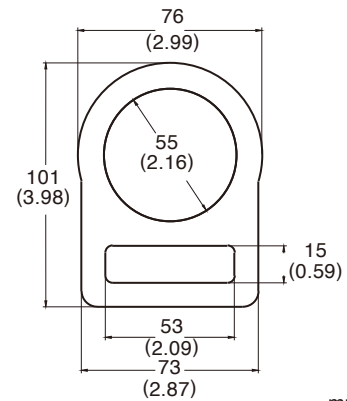

Zinc Plated

mm (inch)

**N-415R
Roller Stamped D-Ring**

Sheet steel, heat treated
 100% proof loaded to 3600 lbs / 16 kN
 Min. Breaking load : 5000 lbs / 23 kN
 Meets :
 ● ANSI Z359.12-2019
 ● CSA Z259.12-16
 Net weight : 5.1 oz. / 145 g

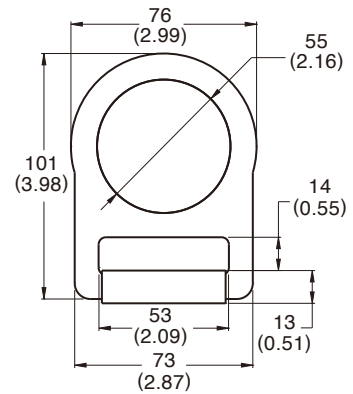

Zinc Plated

mm (inch)

**N-415X
Stamped D-Ring**

Sheet steel, heat treated
 100% proof loaded to 3600 lbs / 16 kN
 Min. Breaking load : 5000 lbs / 23 kN
 Meets :
 ● ANSI Z359.12-2019
 ● CSA Z259.12-16
 Net weight : 3.5 oz. / 100 g

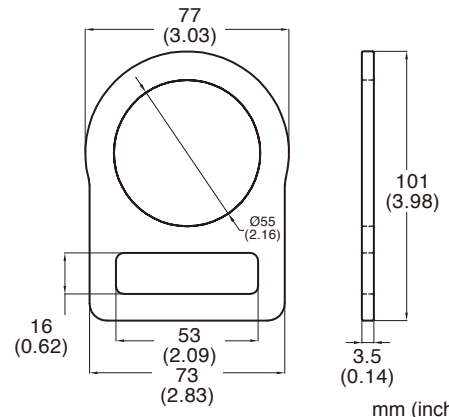

Zinc Plated

mm (inch)

**N-419
Stamped D-Ring**

Sheet steel, heat treated
 100% proof loaded to 3600 lbs / 16 kN
 Min. Breaking load : 5000 lbs / 23 kN
 Meets :
 ● ANSI Z359.12-2019
 ● CSA Z259.12-16
 Net weight : 4.8 oz. / 136 g

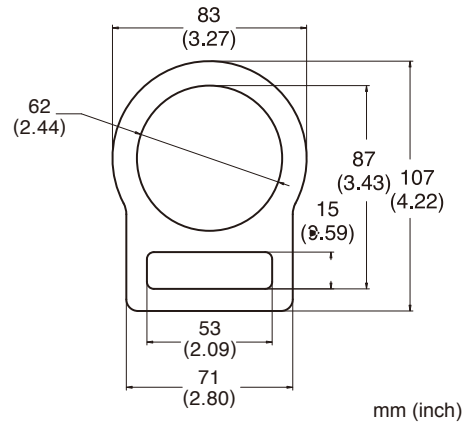

Zinc Plated

**N-419R
Roller Stamped D-Ring**

Sheet steel, heat treated
 100% proof loaded to 3600 lbs / 16 kN
 Min. Breaking load : 5000 lbs / 23 kN
 Meets :
 ● ANSI Z359.12-2019
 ● CSA Z259.12-16
 Net weight : 5.0 oz. / 142 g

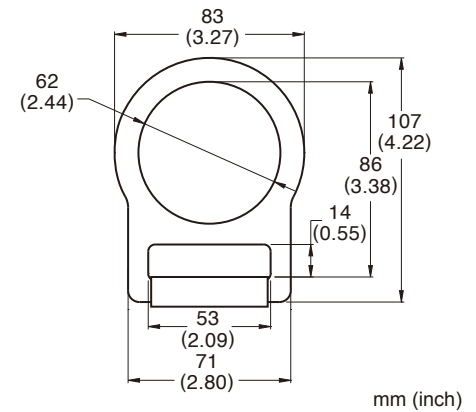

Zinc Plated

**N-477
Stamped Bent D-Ring**

Sheet steel, heat treated
 100% proof loaded to 3600 lbs / 16 kN
 Min. Breaking load : 5000 lbs / 23 kN
 Meets :
 ● ANSI Z359.12-2019
 ● CSA Z259.12-16
 Net weight : 4.8 oz. / 138 g

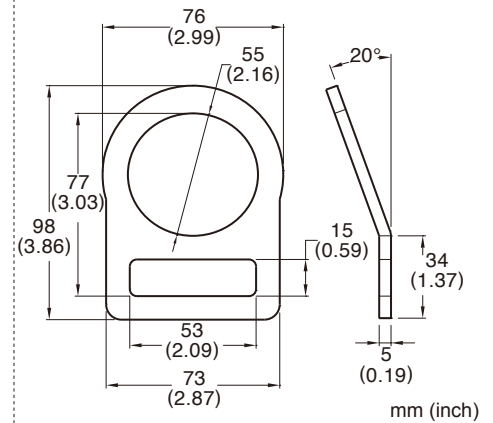

Zinc Plated

**N-417
D-Ring**

Forged steel, heat treated
 100% proof loaded to 3600 lbs / 16 kN
 Min. Breaking load : 5000 lbs / 23 kN
 Meets :
 ● ANSI Z359.12-2019
 ● CSA Z259.12-16
 Net weight : 8.0 oz. / 227 g

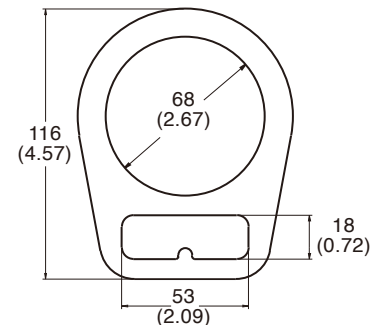

Zinc Plated

mm (inch)

**N-437
Bent D-Ring**

Forged steel, heat treated
 100% proof loaded to 3600 lbs / 16 kN
 Min. Breaking load : 5000 lbs / 23 kN
 Meets :
 ● ANSI Z359.12-2019
 ● CSA Z259.12-16
 Net weight : 7.9 oz. / 225 g

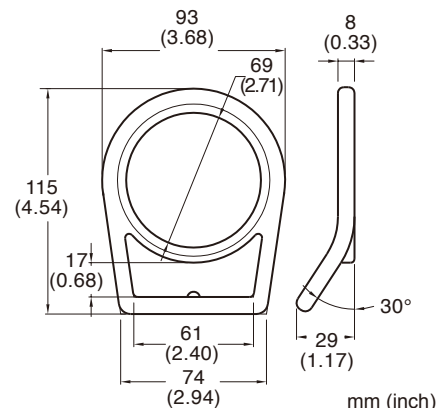

Zinc Plated

**N-476
D-Ring**

Forged steel, heat treated
 100% proof loaded to 3600 lbs / 16 kN
 Min. Breaking load : 5000 lbs / 23 kN
 Meets :
 ● ANSI Z359.12-2019
 ● CSA Z259.12-16
 Net weight : 7.9 oz. / 225 g

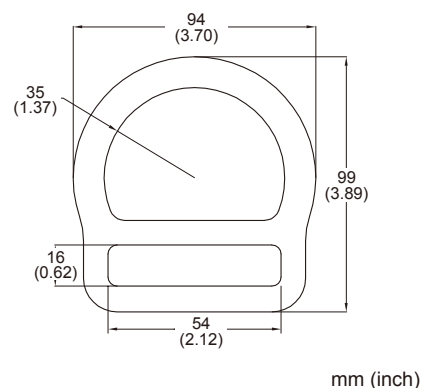

Zinc Plated

**N-476R
Roller D-Ring**

Forged steel, heat treated
 100% proof loaded to 3600 lbs / 16 kN
 Min. Breaking load : 5000 lbs / 23 kN
 Meets :
 ● ANSI Z359.12-2019
 ● CSA Z259.12-16
 Net weight : 8.0 oz. / 227 g

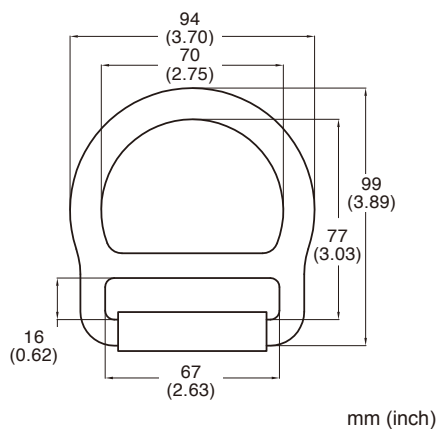

Zinc Plated

**N-455
Stamped D-Ring**

Sheet steel, heat treated
 100% proof loaded to 3600 lbs / 16 kN
 Min. Breaking load : 5000 lbs / 23 kN
 Meets :
 ● ANSI Z359.12-2019
 ● CSA Z259.12-16
 Net weight : 4.2 oz. / 120 g

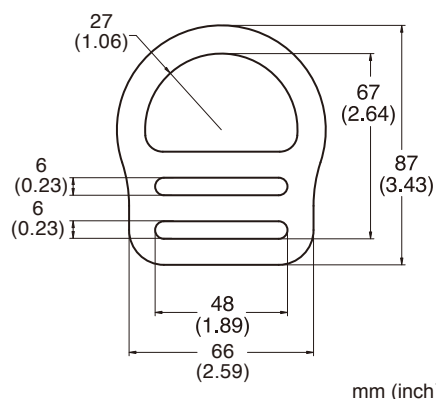

Zinc Plated

**N-4053
3-Bar D-Ring**

Forged steel, heat treated
 100% proof loaded to 3600 lbs / 16 kN
 Min. Breaking load : 5000 lbs / 23 kN
 Meets :
 ● ANSI Z359.12-2019
 ● CSA Z259.12-16
 Net weight : 3.49 oz. / 99 g

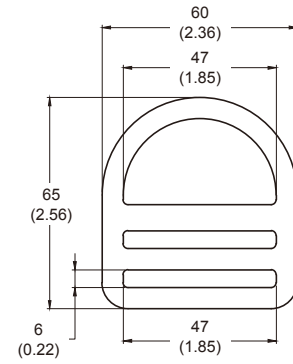

mm (inch)

Zinc Plated

**N-460
D-Ring**

Forged steel, heat treated
 100% proof loaded to 3600 lbs / 16 kN
 Min. Breaking load : 5000 lbs / 23 kN
 Meets :
 ● ANSI Z359.12-2019
 ● CSA Z259.12-16
 Net weight : 6.9 oz. / 180 g

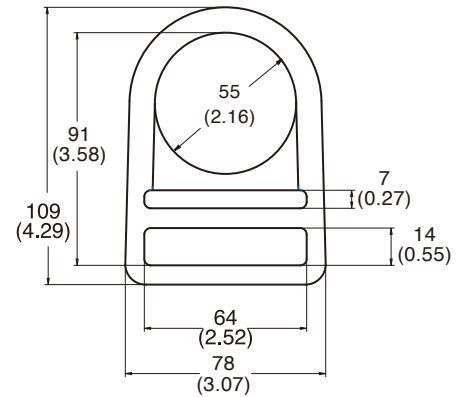

mm (inch)

Zinc Plated

**N-461
D-Ring**

Forged steel, heat treated
 100% proof loaded to 3600 lbs / 16 kN
 Min. Breaking load : 5000 lbs / 23 kN
 Meets :
 ● ANSI Z359.12-2019
 ● CSA Z259.12-16
 Net weight : 5.9 oz. / 170 g

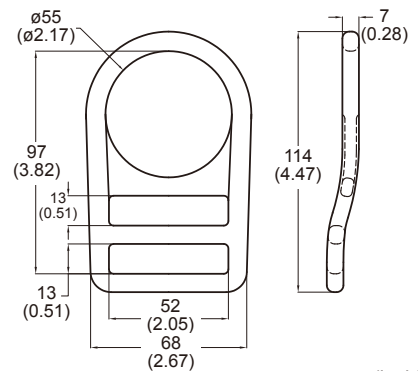

mm (inch)

Zinc Plated

**N-469
D-Ring with Clip**

Forged steel, heat treated
 100% proof loaded to 3600 lbs / 16 kN
 Min. Breaking load : 5000 lbs / 23 kN
 Meets :
 ● ANSI Z359.12-2019
 ● CSA Z259.12-16
 Net weight : 9.4 oz. / 269 g

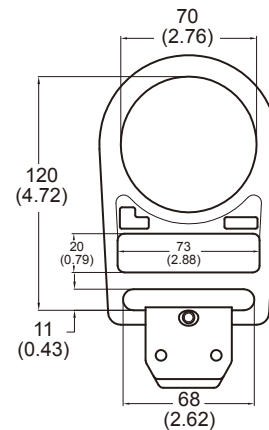

mm (inch)

Zinc Plated

**N-478
Bent D-Ring**

Forged steel, heat treated
 100% proof loaded to 3600 lbs / 16 kN
 Min. Breaking load : 5000 lbs / 23 kN
 Meets :
 ● ANSI Z359.12-2019
 ● CSA Z259.12-16
 Net weight : 3.8 oz. / 108 g

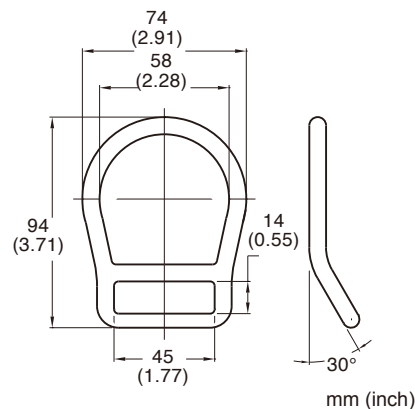

Zinc Plated

**N-493
Stamped D-Ring**

Sheet steel, heat treated
 100% proof loaded to 3600 lbs / 16kN
 Min. Breaking load : 5000 lbs / 23 kN
 Meets :
 ● ANSI Z359.12-2019
 ● CSA Z259.12-16
 Net weight : 2.78oz. / 79g

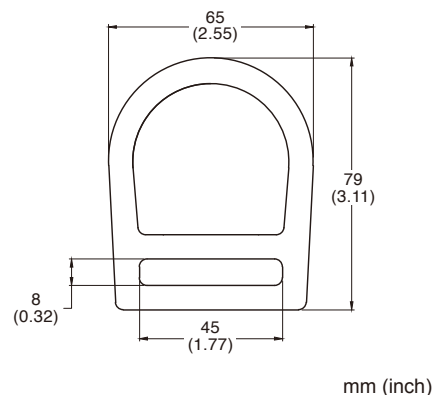

Zinc Plated

**N-493-BT
Stamped Bent D-Ring**

Sheet steel, heat treated
 100% proof loaded to 3600 lbs / 16kN
 Min. Breaking load : 5000 lbs / 23 kN
 Meets :
 ● ANSI Z359.12-2019
 ● CSA Z259.12-16
 Net weight : 2.78oz. / 79g

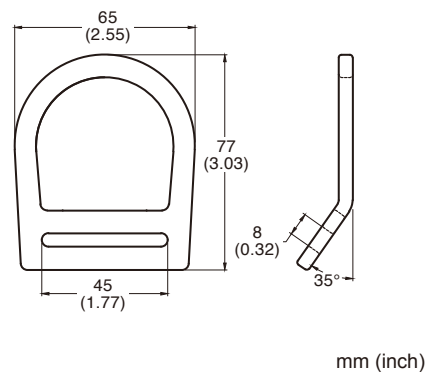

Zinc Plated

**N-492
D-Ring**

Forged steel, heat treated
 100% proof loaded to 3600 lbs / 16kN
 Min. Breaking load : 5000 lbs / 23 kN
 Meets :
 ● ANSI Z359.12-2019
 ● CSA Z259.12-16
 Net weight : 4.48oz. / 127g

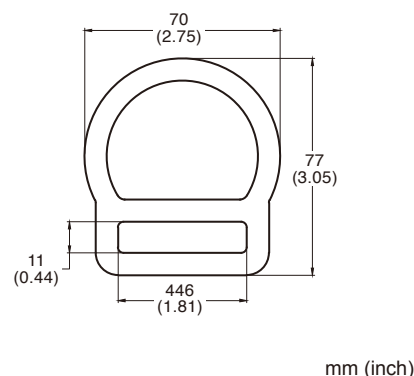

Zinc Plated

**N-492-BT
Bent D-Ring**

Forged steel, heat treated
 100% proof loaded to 3600 lbs / 16kN
 Min. Breaking load : 5000 lbs / 23 kN
 Meets :
 ● ANSI Z359.12-2019
 ● CSA Z259.12-16
 Net weight : 4.48oz. / 127g

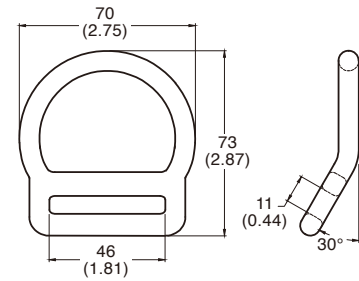

Zinc Plated

mm (inch)

**N-403XL
D-Ring**

Sheet steel, heat treated
 100% proof loaded to 3600 lbs / 16 kN
 Min. Breaking load : 5000 lbs / 23 kN
 Meets :
 ● ANSI Z359.12-2019
 ● CSA Z259.12-16
 Net weight : 2.5 oz. / 71 g



Light Weight Designed

New

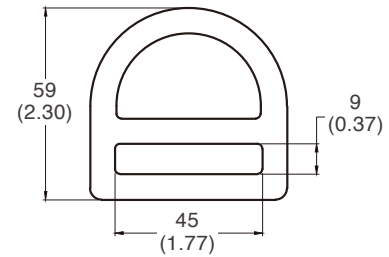

Zinc Plated

mm (inch)

**N-403L
Stamped D-Ring**

Sheet steel, heat treated
 100% proof loaded to 3600 lbs / 16 kN
 Min. breaking load : 5000 lbs / 23 kN
 Meets :
 ● ANSI Z359.12-2019
 ● CSA Z259.12-16
 Net weight : 2.8 oz. / 78 g

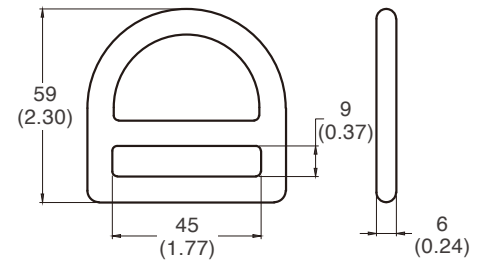

Zinc Plated

mm (inch)

**N-403
D-Ring**

Forged steel, heat treated
 100% proof loaded to 3600 lbs / 16 kN
 Min. Breaking load : 5000 lbs / 23 kN
 Meets :
 ● ANSI Z359.12-2019
 ● CSA Z259.12-16
 Net weight : 2.8 oz. / 80 g

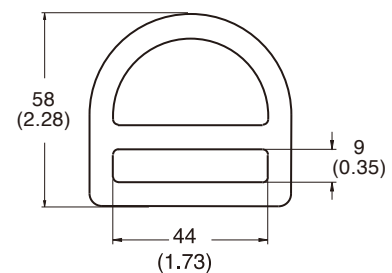

Zinc Plated

mm (inch)

**N-445
Bent D-Ring**

Forged steel, heat treated
 100% proof loaded to 3600 lbs / 16 kN
 Min. Breaking load : 5000 lbs / 23 kN

Meets :

- ANSI Z359.12-2019
- CSA Z259.12-16

Net weight : 3.1 oz. / 90 g

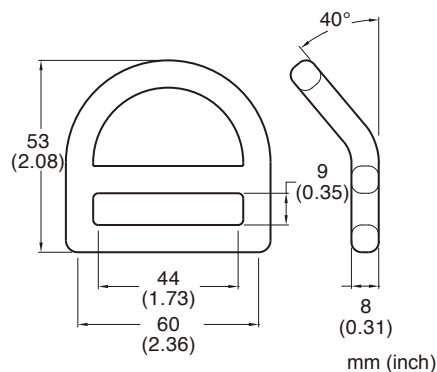

Zinc Plated

**N-445L
Stamped Bent D-Ring**

Sheet steel, heat treated
 100% proof loaded to 3600 lbs / 16 kN
 Min. breaking load : 5000 lbs / 23 kN

Meets :

- ANSI Z359.12-2019
- CSA Z259.12-16

Net weight : 2.8 oz. / 80 g

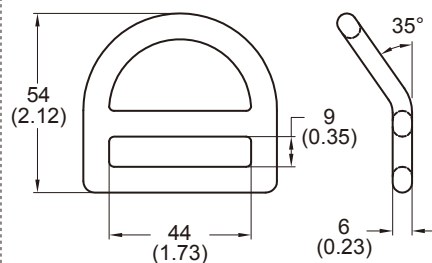

Zinc Plated

mm (inch)

**N-430
Stamped D-Ring, with bar**

Sheet steel, heat treated
 100% proof loaded to 3600 lbs / 16 kN
 Mini. Breaking load : 5000 lbs / 23 kN
 Meets :
 ● ANSI Z359.12-2019
 ● CSA Z259.12-16
 Net weight : 3.1 oz. / 90 g

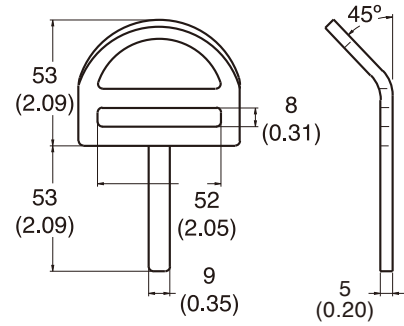

Zinc Plated

mm (inch)

**N-432
Stamped D-Ring**

Sheet steel, heat treated
 100% proof loaded to 3600 lbs / 16 kN
 Mini. Breaking load : 5000 lbs / 23 kN
 Meets :
 ● ANSI Z359.12-2019
 ● CSA Z259.12-16
 Net weight : 2.8 oz. / 80 g.

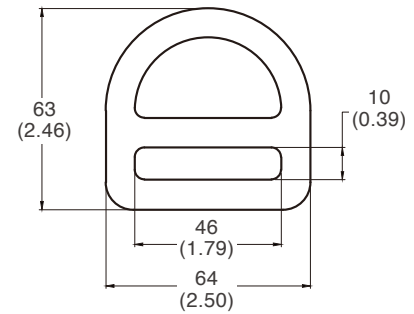

Zinc Plated

mm (inch)

**N-431
Stamped Bent D-Ring**

Sheet steel, heat treated
 100% proof loaded to 3600 lbs / 16 kN
 Mini. Breaking load : 5000 lbs / 23 kN
 Meets :
 ● ANSI Z359.12-2019
 ● CSA Z259.12-16
 Net weight : 2.8 oz. / 80 g

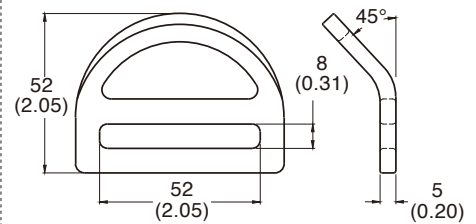

Zinc Plated

mm (inch)

**N-405
D-Ring**

Forged steel, heat treated
 100% proof loaded to 3600 lbs / 16 kN
 Min. Breaking load : 5000 lbs / 23 kN
 Meets :
 ● ANSI Z359.12-2019
 ● CSA Z259.12-16
 Net weight : 3.1 oz. / 88 g

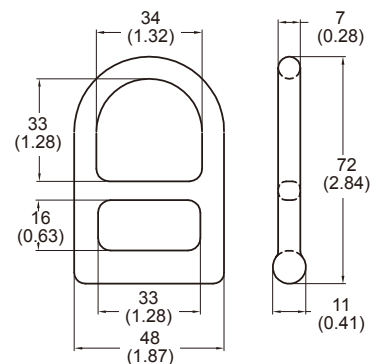

Zinc Plated

mm (inch)

**N-4052
Stamped Bent D-Ring**

Sheet steel, heat treated
 100% proof loaded to 3600 lbs / 16 kN
 Min. Breaking load : 5000 lbs / 23 kN
 Meets :
 ● ANSI Z359.12-2019
 ● CSA Z259.12-16
 Net weight : 4.97 oz. / 141 g

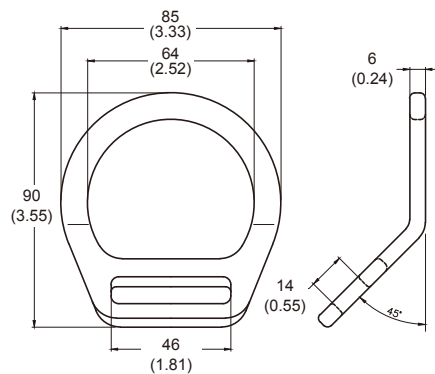

mm (inch)

Zinc Plated

**N-407L
Stamped D-Ring**

Sheet steel, heat treated
 100% proof loaded to 3600 lbs / 16 kN
 Mini. Breaking load : 5000 lbs / 23 kN
 Meets :
 ● ANSI Z359.12-2019
 ● CSA Z259.12-16
 Net weight : 2.8 oz. / 78 g

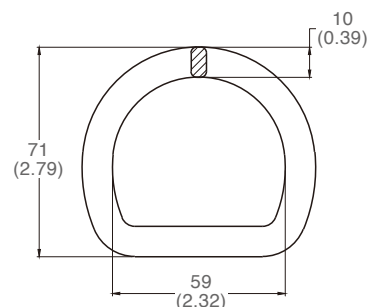

mm (inch)

Zinc Plated

**N-4021L
Stamped D-Ring**

Sheet steel, heat treated
 100% proof loaded to 3600 lbs / 16 kN
 Mini. Breaking load : 5000 lbs / 23 kN
 Meets :
 ● ANSI Z359.12-2019
 ● CSA Z259.12-16
 Net weight : 2.8 oz. / 80 g

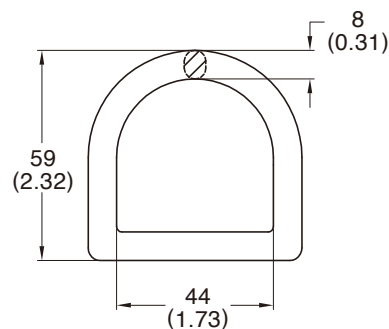

mm (inch)

Zinc Plated

**N-2817
D Ring with Bracket Weldment**

Sheet steel, heat treated
 Min. Breaking load : 5000 lbs / 23 kN
 Meets:
 ● ANSI Z359.12-2019
 ● CSA Z259.12-16
 Net weight : 9.5 oz. / 268 g

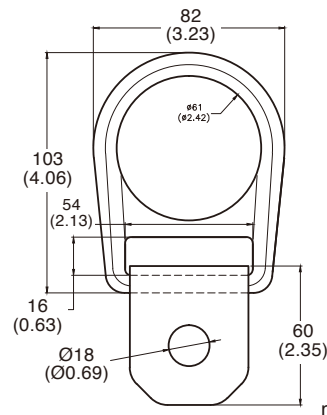

mm (inch)

yellow zinc

New

**N-407
D-Ring**

Forged steel, heat treated
 100% proof loaded to 3600 lbs / 16 kN
 Min. Breaking load : 5000 lbs / 23 kN
 Meets :
 ● ANSI Z359.12-2019
 ● CSA Z259.12-16
 Net weight : 4.4 oz. / 126 g

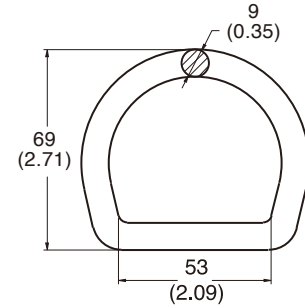

Zinc Plated

mm (inch)

**N-407R
Roller D-Ring**

Forged steel, heat treated
 100% proof loaded to 3600 lbs / 16 kN
 Min. Breaking load : 5000 lbs / 23 kN
 Meets :
 ● ANSI Z359.12-2019
 ● CSA Z259.12-16
 Net weight : 4.5 oz. / 129 g

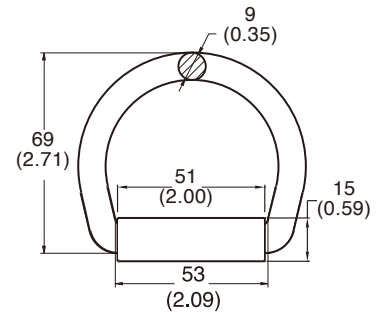

Zinc Plated

mm (inch)

**N-408
D-Ring**

Forged steel, heat treated
 100% proof loaded to 3600 lbs / 16 kN
 Min. Breaking load : 5000 lbs / 23 kN
 Meets :
 ● ANSI Z359.12-2019
 ● CSA Z259.12-16
 Net weight : 5.3 oz. / 150 g

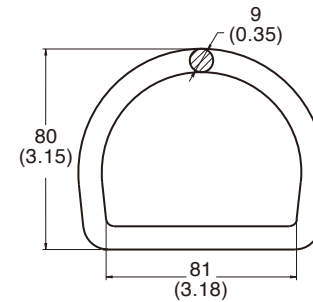

Zinc Plated

mm (inch)

**N-408R
Roller D-Ring**

Forged steel, heat treated
 100% proof loaded to 3600 lbs / 16 kN
 Min. Breaking load : 5000 lbs / 23 kN
 Meets :
 ● ANSI Z359.12-2019
 ● CSA Z259.12-16
 Net weight : 5.4 oz. / 153 g

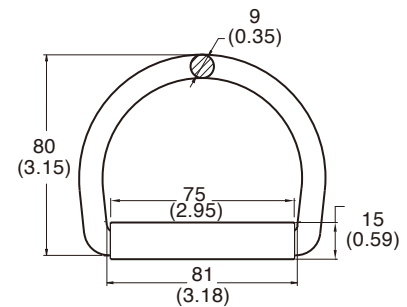

Zinc Plated

mm (inch)

**N-402
D-Ring**

Forged steel, heat treated
 100% proof loaded to 3600 lbs / 16 kN
 Mini. Breaking load : 5000 lbs / 23 kN
 Meets :
 ● ANSI Z359.12-2019
 ● CSA Z259.12-16
 Net weight : 3.0 oz. / 86 g

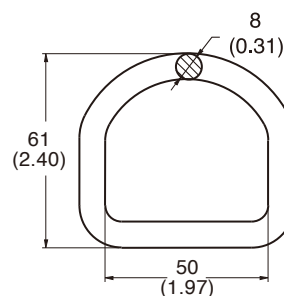

Zinc Plated

mm (inch)

**N-402W
Welded D-Ring**

Steel
 Min. Breaking load : 5000 lbs / 23 kN
 Net weight : 2.33 oz. / 66 g

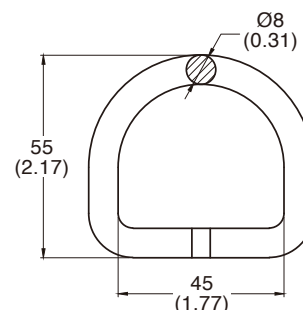

Zinc Plated

mm (inch)

**N-404
Stamped D-Ring**

Sheet steel, heat treated
 100% proof loaded to 3600 lbs / 16 kN
 Min. Breaking load : 5000 lbs / 23 kN
 Meets :
 ● ANSI Z359.12-2019
 ● CSA Z259.12-16
 Net weight : 2.5 oz. / 70 g

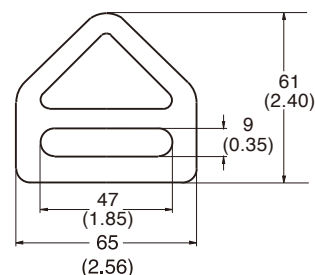

Zinc Plated

mm (inch)

**N-404R
Stamped Roller D-Ring**

Sheet steel, heat treated
 100% proof loaded to 3600 lbs / 16 kN
 Min. Breaking load : 5000 lbs / 23 kN
 Meets :
 ● ANSI Z359.12-2019
 ● CSA Z259.12-16
 Net weight : 2.8 oz. / 77 g

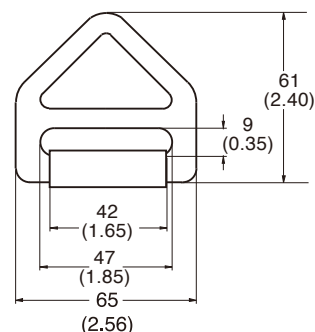

Zinc Plated

mm (inch)

**N-429
Delta D-Ring**

Forged steel, heat treated
 100% proof loaded to 3600 lbs / 16 kN
 Min. Breaking load : 5000 lbs / 23 kN
 Meets :
 ● ANSI Z359.12-2019
 ● CSA Z259.12-16
 Net weight : 1.6 oz. / 45 g

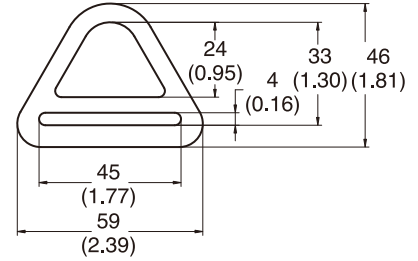

Zinc Plated

mm (inch)

**N-475
D-Ring**

Forged steel, heat treated
 100% proof loaded to 3600 lbs / 16 kN
 Min. Breaking load : 5000 lbs / 23 kN
 Meets :
 ● ANSI Z359.12-2019
 ● CSA Z259.12-16
 Net weight : 4.2 oz. / 120 g

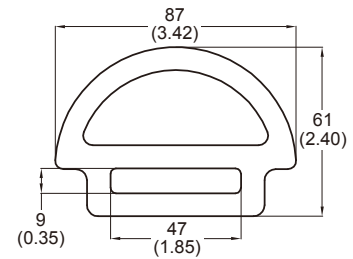

Zinc Plated

mm (inch)

**N-449
D-Ring**

Forged steel, heat treated
 100% proof loaded to 3600 lbs / 16 kN
 Min. Breaking load : 5000 lbs / 23 kN
 Meets :
 ● ANSI Z359.12-2019
 ● CSA Z259.12-16
 Net weight : 2.1 oz. / 60 g

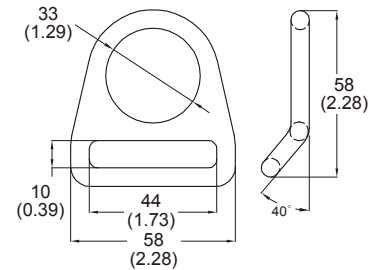

Zinc Plated

mm (inch)

**N-406
D-Ring**

Forged steel, heat treated
 100% proof loaded to 3600 lbs / 16 kN
 Min. Breaking load : 5000 lbs / 23 kN
 Meets :
 ● ANSI Z359.12-2019
 ● CSA Z259.12-16
 Net weight : 4.0 oz. / 120 g

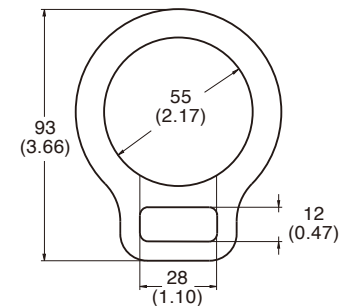

Zinc Plated

mm (inch)

**N-487
Stamped O Ring**

Sheet steel, heat treated
 100% proof loaded to 3600 lbs / 16kN
 Min. Breaking load : 5000 lbs / 23 kN
 Meets :
 ● ANSI Z359.12-2019
 ● CSA Z259.12-16
 Net weight : 2.0 oz. / 57 g

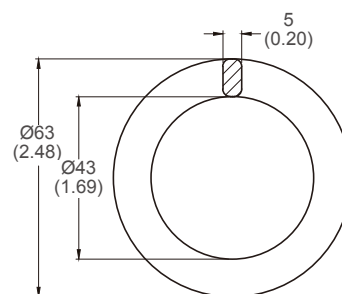

Zinc Plated

mm (inch)

**N-486
O Ring**

Forged steel, heat treated
 100% proof loaded to 3600 lbs / 16 kN
 Min. Breaking load : 5000 lbs / 23 kN
 Meets :
 ● ANSI Z359.12-2019
 ● CSA Z259.12-16
 Net weight : 2.1 oz. / 60 g

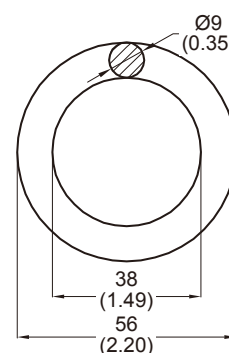

Zinc Plated

mm (inch)

**N-453
O Ring**

Forged steel, heat treated
 100% proof loaded to 3600 lbs / 16 kN
 Min. Breaking load : 5000 lbs / 23 kN
 Meets :
 ● ANSI Z359.12-2019
 ● CSA Z259.12-16
 Net weight : 5.0 oz. / 150 g

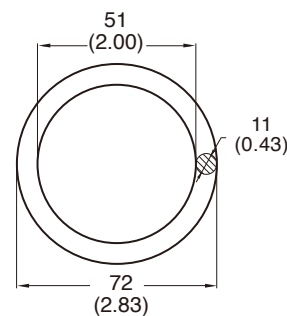

Zinc Plated

mm (inch)

**N-483
O Ring**

Forged steel, heat treated
 100% proof loaded to 3600 lbs / 16 kN
 Min. Breaking load : 5000 lbs / 23 kN
 Meets :
 ● ANSI Z359.12-2019
 ● CSA Z259.12-16
 Net weight : 5.2 oz. / 146 g

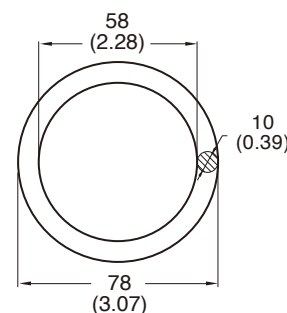

Zinc Plated

mm (inch)

**N-489
O Ring**

Forged steel, heat treated
 100% proof loaded to 3600 lbs / 16 kN
 Min. Breaking load : 5000 lbs / 23 kN
 Meets :
 ● ANSI Z359.12-2019
 ● CSA Z259.12-16
 Net weight : 7.0 oz. / 198 g

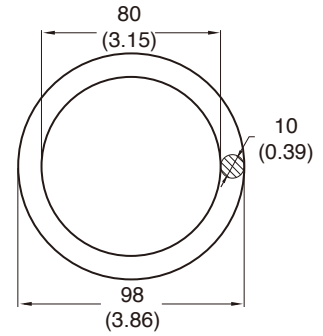

Zinc Plated

mm (inch)

**N-422
Quick Buckle**

Sheet steel, heat treated
 Min. Breaking load : 4000 lbs / 18 kN
 Meets :
 ● ANSI Z359.12-2019
 ● CSA Z259.12-16
 Net weight : 1.0 oz. / 28 g

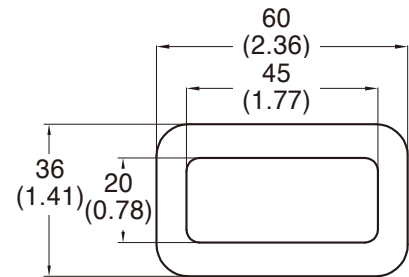

Zinc Plated

mm (inch)

**N-4226
Quick Buckle**

Sheet steel, heat treated
 Min. Breaking load : 4000 lbs / 18 kN
 Meets :
 ● ANSI Z359.12-2019
 ● CSA Z259.12-16
 Net weight : 1.4 oz. / 39 g

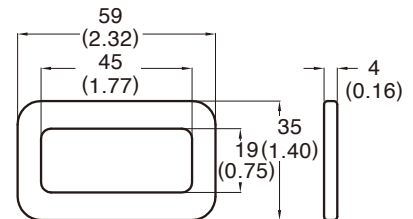

Zinc Plated

mm (inch)

**N-4224
Quick Buckle**

Sheet steel, heat treated
 Min. Breaking load : 4000 lbs / 18 kN
 Meets :
 ● ANSI Z359.12-2019
 ● CSA Z259.12-16
 Net weight : 1.9 oz. / 55.2 g

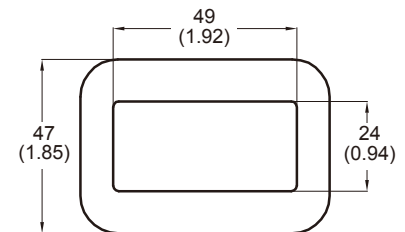

Zinc Plated

mm (inch)

**N-442
Loop Adjuster**

Sheet steel, heat treated
 Min. Breaking load : 4000 lbs / 18 kN
 Meets :
 ● ANSI Z359.12-2019
 ● CSA Z259.12-16
 Net weight : 0.6 oz. / 17 g

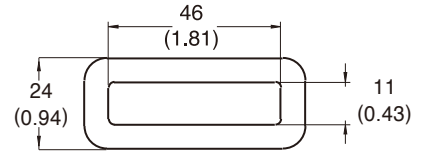

Zinc Plated

mm (inch)

**N-401
Quick Buckle**

Sheet steel, heat treated
 Min. Breaking load : 4000 lbs / 18 kN
 Meets :
 ● ANSI Z359.12-2019
 ● CSA Z259.12-16
 Net weight : 1.9 oz. / 54 g

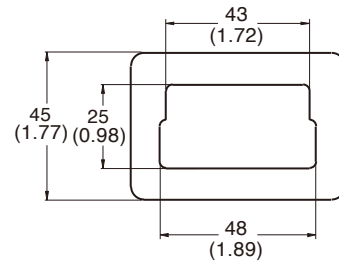

Zinc Plated

*Supplied without sliding pin

mm (inch)

**N-4011
Quick Buckle**

Sheet steel, heat treated
 Min. Breaking load : 4000 lbs / 18 kN
 Meets :
 ● ANSI Z359.12-2019
 ● CSA Z259.12-16
 Net weight : 1.3 oz. / 38 g

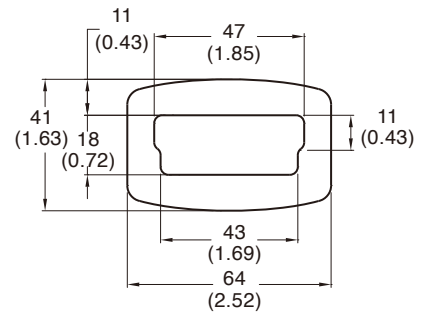

Zinc Plated

mm (inch)

**N-4012
Quick Buckle**

Sheet steel, heat treated
 Min. Breaking load : 4000 lbs / 18 kN
 Meets :
 ● ANSI Z359.12-2019
 ● CSA Z259.12-16
 Net weight : 1.9 oz. / 55 g

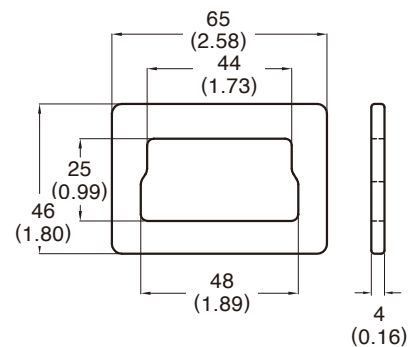

Zinc Plated

mm (inch)

**N-4016
Quick Buckle**

Sheet steel, heat treated
 Min. Breaking load : 4000 lbs / 18 kN
 Meets :
 ● ANSI Z359.12-2019
 ● CSA Z259.12-16
 Net weight : 1.9 oz. / 53 g

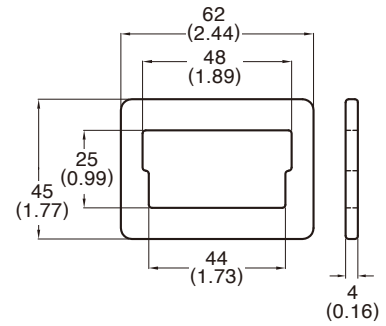

Zinc Plated

mm (inch)

**N-4013
Quick Buckle**

Sheet steel, heat treated
 Min. Breaking load : 4000 lbs / 18 kN
 Meets :
 ● ANSI Z359.12-2019
 ● CSA Z259.12-16
 Net weight : 1.3 oz. / 37 g

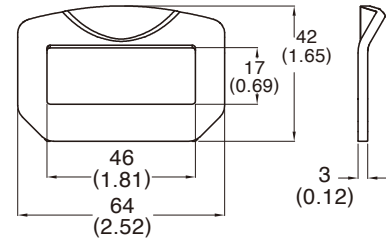

Zinc Plated

mm (inch)

**N-4014
Quick Buckle**

Sheet steel, heat treated
 Min. Breaking load : 4000 lbs / 18 kN
 Meets :
 ● ANSI Z359.12-2019
 ● CSA Z259.12-16
 Net weight : 0.8 oz. / 23 g

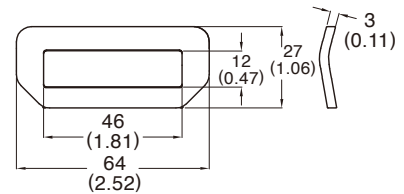

Zinc Plated

mm (inch)

**N-428
Quick Buckle**

Sheet steel, heat treated
 Min. Breaking load : 4000 lbs / 18 kN
 Meets :
 ● ANSI Z359.12-2019
 ● CSA Z259.12-16
 Net weight : 0.5 oz. / 15 g

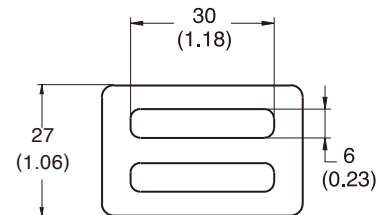

Zinc Plated

mm (inch)

**N-434
Stamped Adjuster**

Sheet steel, heat treated
 Min. Breaking Load : 4000 lbs / 18 kN
 Meets :
 ● ANSI Z359.12-2019
 ● CSA Z259.12-16
 Net weight : 1.4 oz. / 41 g

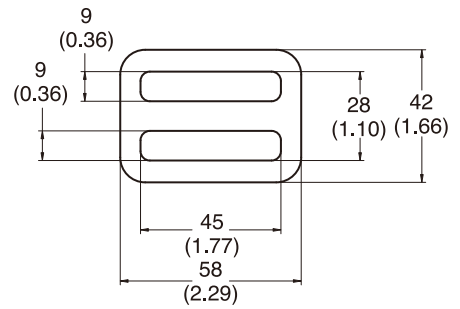

Zinc Plated

mm (inch)

**N-420
Quick Buckle**

Sheet steel, heat treated
 Min. Breaking load : 4000 lbs / 18 kN
 Meets :
 ● ANSI Z359.12-2019
 ● CSA Z259.12-16
 Net weight : 1.0 oz. / 27 g

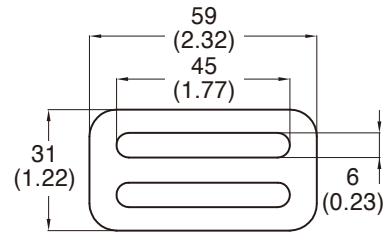

Zinc Plated

mm (inch)

**N-4201
Quick Buckle**

Sheet steel, heat treated
 Min. Breaking load : 4000 lbs / 18 kN
 Meets :
 ● ANSI Z359.12-2019
 ● CSA Z259.12-16
 Net weight : 1.3 oz. / 38 g

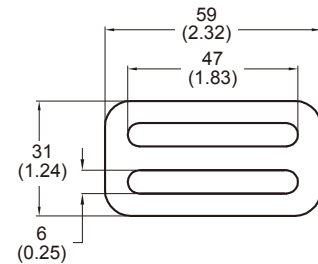

Zinc Plated

mm (inch)

**N-4206
Quick Buckle**

Sheet steel, heat treated
 Min. Breaking load : 4000 lbs / 18 kN
 Meets :
 ● ANSI Z359.12-2019
 ● CSA Z259.12-16
 Net weight : 1.4 oz. / 40 g

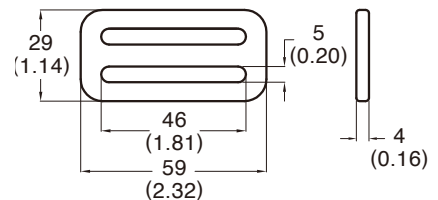

Zinc Plated

mm (inch)

N-435
Slide Buckle - Non-Rated

Sheet steel, heat treated
Min. Tensile strength : 40 lbs / 0.18 kN
Net weight : 0.5 oz. / 13 g

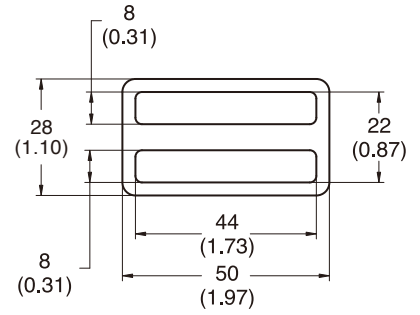

Zinc Plated

mm (inch)

N-421
Quick Buckle

Sheet steel, heat treated
Min. Breaking load : 4000 lbs / 18 kN
Meets :
● ANSI Z359.12-2019
● CSA Z259.12-16
Net weight : 1.3 oz. / 36 g

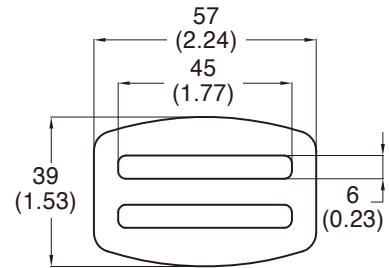

Zinc Plated

mm (inch)

N-4203
Quick Buckle

Sheet steel, heat treated
Min. Breaking load : 4000 lbs / 18 kN
Meets :
● ANSI Z359.12-2019
● CSA Z259.12-16
Net weight : 1.3 oz. / 36 g

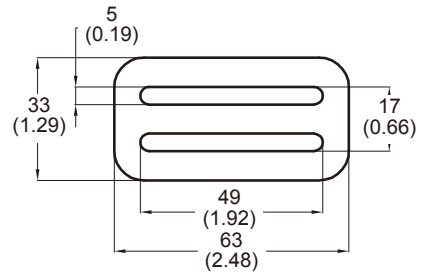
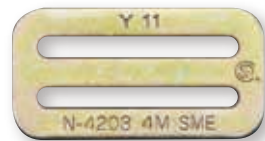

Zinc Plated

mm (inch)

N-4501
Quick Buckle

Sheet steel, heat treated
Min. Breaking load : 4000 lbs / 18 kN
Meets :
● ANSI Z359.12-2019
● CSA Z259.12-16
Net weight : 2.5 oz. / 70 g

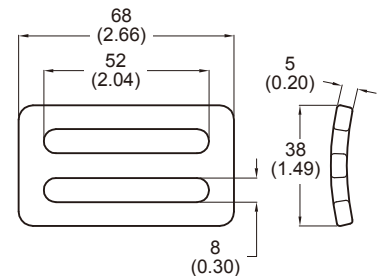

Zinc Plated

mm (inch)

**N-4502
Quick Buckle**

Sheet steel, heat treated
 Min. Breaking load : 4000 lbs / 18 kN
 Meets :
 ● ANSI Z359.12-2019
 ● CSA Z259.12-16
 Net weight : 2.3 oz. / 66 g

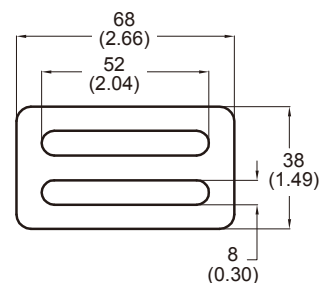

Zinc Plated

mm (inch)

**N-4207
Quick Buckle**

Sheet steel, heat treated
 Min. Breaking load : 4000 lbs / 18 kN
 Meets :
 ● ANSI Z359.12-2019
 ● CSA Z259.12-16
 Net weight : 1.0 oz. / 28 g

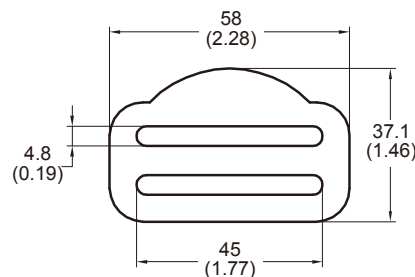

Zinc Plated

mm (inch)

**N-451
Oval Adjuster**

Forged steel, heat treated
 Min. Breaking load : 5000 lbs / 23 kN
 Meets :
 ● ANSI Z359.12-2019
 ● CSA Z259.12-16
 Net weight : 1.9 oz. / 60 g

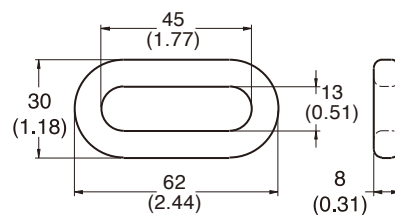

Zinc Plated

mm (inch)

**N-413
Adjuster**

Forged steel, heat treated
 Min. Breaking load : 5000 lbs / 23 kN
 Meets :
 ● ANSI Z359.12-2019
 ● CSA Z259.12-16
 Net weight : 6.1 oz. / 170 g

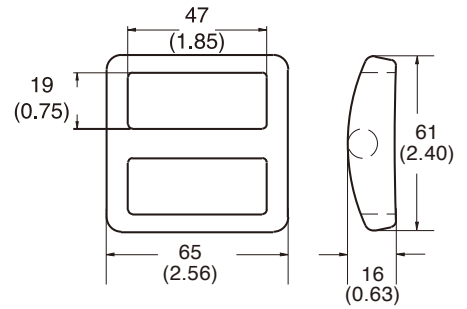

Zinc Plated

mm (inch)

**N-413X
Adjuster**

Sheet steel, heat treated
 Min. Breaking load : 5000 lbs / 23 kN
 Meets :
 ● ANSI Z359.12-2019
 ● CSA Z259.12-16
 Net weight : 3.5 oz. / 100 g

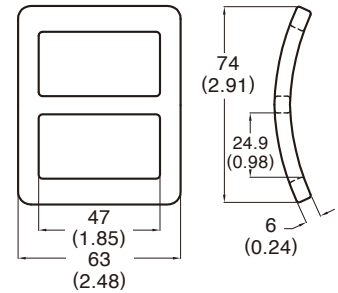

Zinc Plated

mm (inch)

**N-4135
Adjuster**

Forged steel, heat treated
 Min. Breaking load : 5000 lbs / 23 kN
 Meets :
 ● ANSI Z359.12-2019
 ● CSA Z259.12-16
 Net weight : 3.9 oz. / 110 g

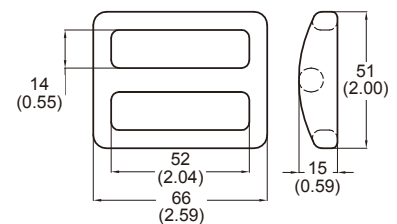

Zinc Plated

mm (inch)

**N-436
Quick Buckle**

Forged steel, heat treated
 Min. Breaking load : 5000 lbs / 23 kN
 Meets :
 ● ANSI Z359.12-2019
 ● CSA Z259.12-16
 Net weight : 2.3 oz. / 65 g

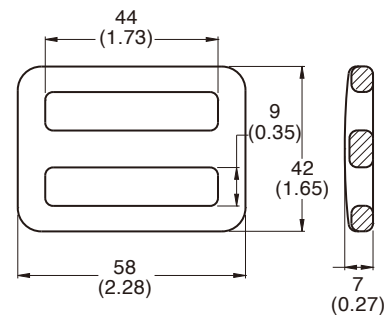

Zinc Plated

mm (inch)

**N-452
Adjuster**

Forged steel, heat treated
 Min. Breaking load : 5000 lbs / 23 kN
 Meets :
 ● ANSI Z359.12-2019
 ● CSA Z259.12-16
 Net weight : 1.6 oz. / 46 g

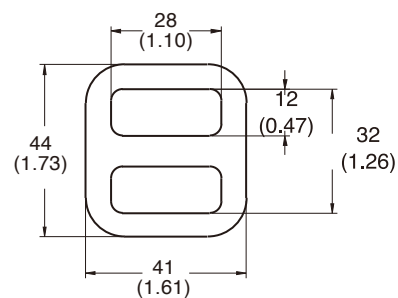

Zinc Plated

mm (inch)

**N-452L
Stamped Adjuster**

Sheet steel, heat treated
 Min. Breaking Load : 5000lbs / 23kN
 Meets :
 ● ANSI Z359.12-2019
 ● CSA Z259.12-16
 Net weight : 1.9 oz. / 53 g

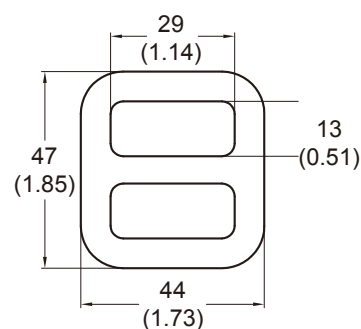

Zinc Plated

mm (inch)

**N-433
Adjuster**

Sheet steel, heat treated
 Min. Breaking load : 4000 lbs / 18 kN
 Meets :
 ● ANSI Z359.12-2019
 ● CSA Z259.12-16
 Net weight : 3.4 oz. / 95 g

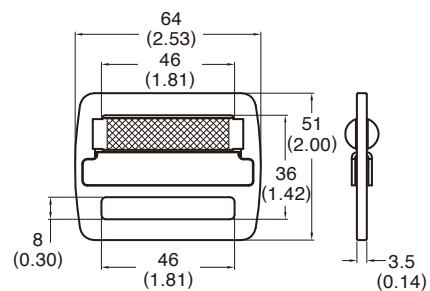

Zinc Plated

mm (inch)

**N-433L
Adjuster**

Sheet steel, heat treated
 Min. Breaking load : 4000 lbs / 18 kN
 Meets :
 ● ANSI Z359.12-2019
 ● CSA Z259.12-16
 Net weight : 3.2 oz. / 90 g

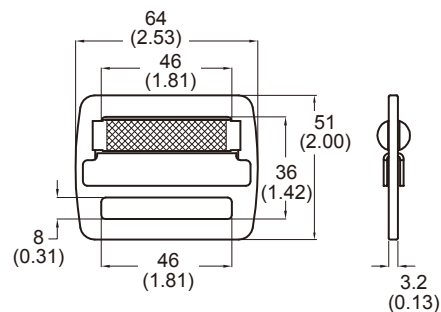

Zinc Plated

mm (inch)

**N-448
Offset Quick Buckle**

Sheet steel, heat treated
 Min. Breaking load : 4000 lbs / 18 kN
 Meets :
 ● ANSI Z359.12-2019
 ● CSA Z259.12-16
 Net weight : 1.8 oz. / 51 g

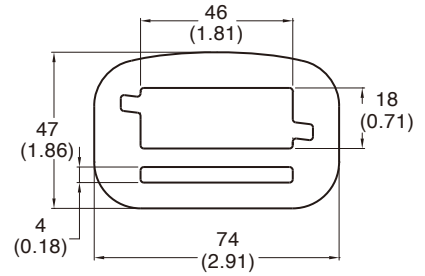

Zinc Plated

mm (inch)

**N-423
Quick Buckle**

Sheet steel, heat treated
 Min. Breaking load : 4000 lbs / 18 kN
 Meets :
 ● ANSI Z359.12-2019
 ● CSA Z259.12-16
 Net weight : 1.8 oz. / 51 g

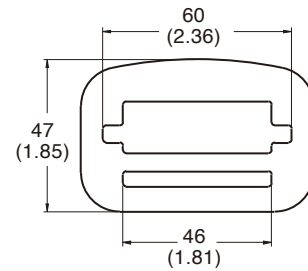

Zinc Plated

mm (inch)

**N-424
Quick Buckle**

Sheet steel, heat treated
 Min. Breaking load : 4000 lbs / 18 kN
 Meets :
 ● ANSI Z359.12-2019
 ● CSA Z259.12-16
 Net weight : 1.2 oz. / 35 g

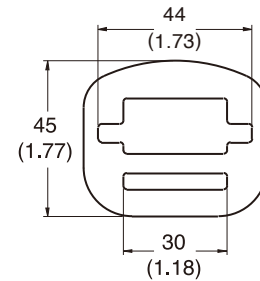

Zinc Plated

mm (inch)

**N-4237
Quick Buckle**

Sheet steel, heat treated
 Min. Breaking load : 4000 lbs / 18 kN
 Meets :
 ● ANSI Z359.12-2019
 ● CSA Z259.12-16
 Net weight : 1.8 oz. / 50 g

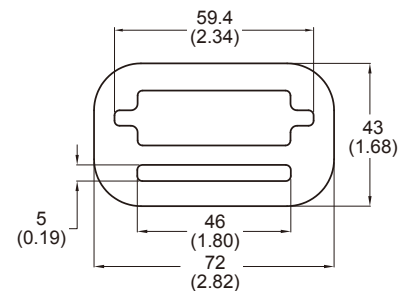

Zinc Plated

mm (inch)

**N-412
Adjuster**

Forged steel, heat treated
 Min. Breaking load : 4000 lbs / 18 kN
 Meets :
 ● ANSI Z359.12-2019
 ● CSA Z259.12-16
 Net weight : 3.1 oz. / 88 g

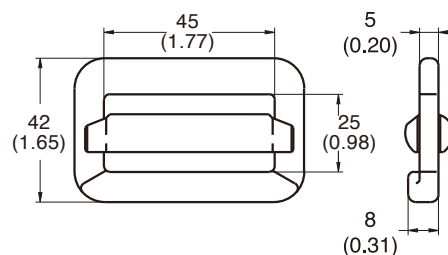

Zinc Plated

mm (inch)

**N-4910
Adjuster Buckle**

Sheet steel, heat treated
 Min. Breaking load : 4000 lbs / 18 kN
 Meets :
 ● ANSI Z359.12-2019
 ● CSA Z259.12-16
 Net weight : 0.9 oz. / 28 g

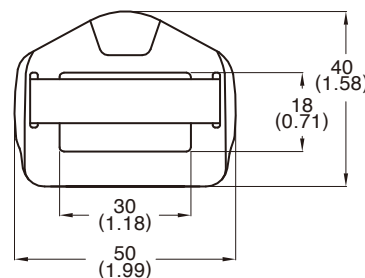

ED Black

mm (inch)

**N-4911
Adjuster Buckle**

Sheet steel, heat treated
 Min. Breaking load : 4000 lbs / 18 kN
 Meets :
 ● ANSI Z359.12-2019
 ● CSA Z259.12-16
 Net weight : 1.5 oz. / 45 g

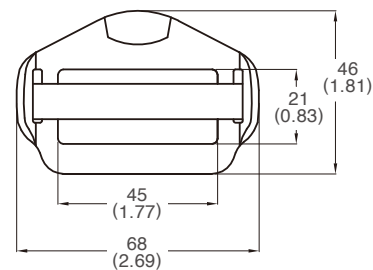

ED Black

mm (inch)

**N-4940-BZP
Quick Buckle**

Sheet steel, heat treated
 Net weight : 0.6 oz. / 16 g

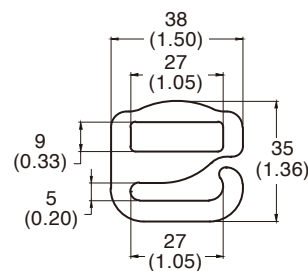

New

Black Zinc

mm (inch)

**N-4941
Quick Buckle**

Sheet steel, heat treated
Net weight : 1.0 oz. / 29 g



New

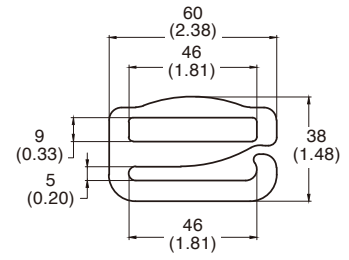

Yellow Zinc

mm (inch)

**N-443
Adjuster Buckle**

Sheet steel, heat treated
Min. Breaking load : 4000 lbs / 18 kN
Meets :
 ● ANSI Z359.12-2019
 ● CSA Z259.12-16
 Net weight : 1.8 oz. / 50 g

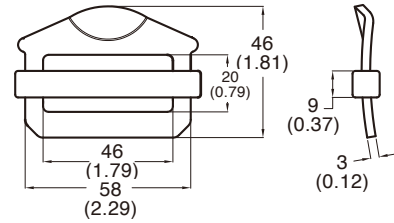
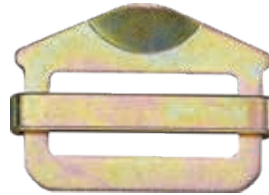

Zinc Plated

mm (inch)

**N-400
Adjuster**

Sheet steel, heat treated
 Min. Breaking Load : 4000 lbs / 18 kN
 Meets :
 ● ANSI Z359.12-2019
 ● CSA Z259.12-16
 Net weight : 3.3 oz. / 93 g

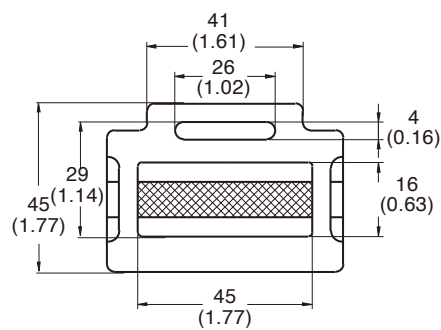

mm (inch)

Zinc Plated

**N-400 / S
Adjuster with spring**

Sheet steel, heat treated
 Min. Breaking Load : 4000 lbs / 18 kN
 Meets :
 ● ANSI Z359.12-2019
 ● CSA Z259.12-16
 Net weight : 3.4 oz. / 96 g

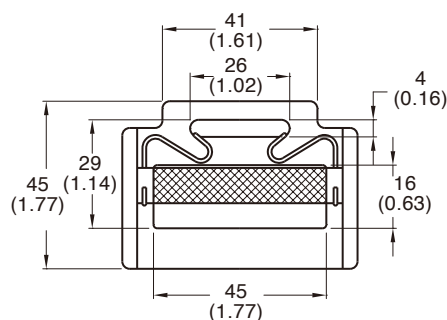

mm (inch)

Zinc Plated

**N-4001
Adjuster**

Sheet steel, heat treated
 Min. Breaking load : 4000 lbs / 18 kN
 Meets :
 ● ANSI Z359.12-2019
 ● CSA Z259.12-16
 Net weight : 2.8 oz. / 80 g

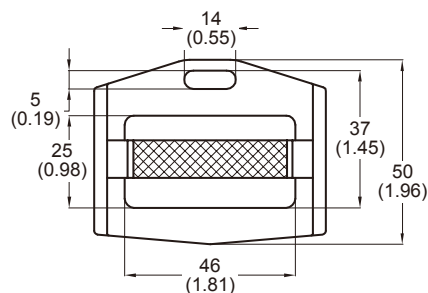

mm (inch)

Zinc Plated

**N-411
Adjuster D-Ring**

Forged steel, heat treated
 100% proof loaded to 3600 lbs / 16 kN
 Min. Breaking load : 5000 lbs / 23 kN
 Meets :
 ● ANSI Z359.12-2019
 ● CSA Z259.12-16
 Net weight : 4.2 oz. / 118 g

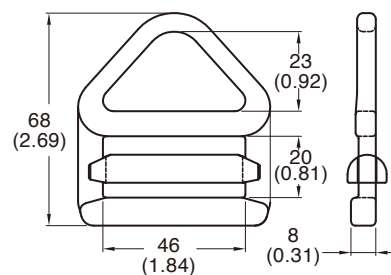

mm (inch)

Zinc Plated

N-4335

**Bent Adjuster Buckle
with silding bar adjuster**

Sheet steel, heat treated

Min. Breaking load : 4000 lbs / 18 kN

Meets :

- ANSI Z359.12-2019
- CSA Z259.12-16

Net weight : 2.8 oz. / 78 g

Zinc Plated

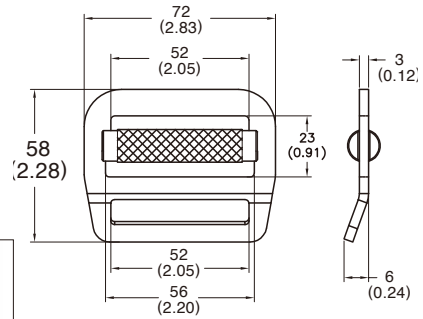
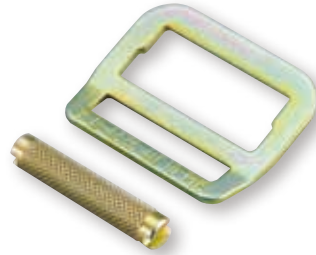

mm (inch)

N-425

**Adjuster Buckle
with silding bar adjuster**

Sheet steel, heat treated

Min. Breaking load : 4000 lbs / 18 kN

Meets :

- ANSI Z359.12-2019
- CSA Z259.12-16

Net weight : 2.4 oz. / 67 g

Zinc Plated

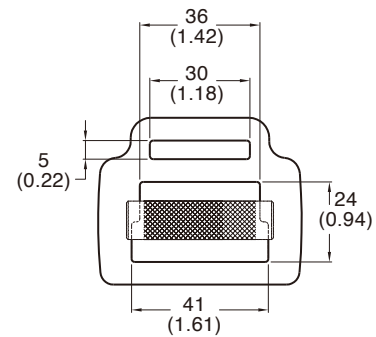

mm (inch)

N-426

**Bent Adjuster Buckle
with silding bar adjuster**

Sheet steel, heat treated

Min. Breaking load : 4000 lbs / 18 kN

Meets :

- ANSI Z359.12-2019
- CSA Z259.12-16

Net weight : 3.1 oz. / 88 g

Zinc Plated

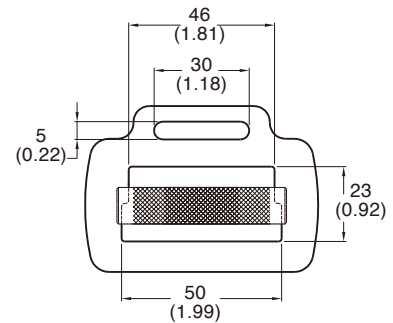

mm (inch)

N-427

**Adjuster Buckle
with silding bar adjuster**

Sheet steel, heat treated

Min. Breaking load : 4000 lbs / 18 kN

Meets :

- ANSI Z359.12-2019
- CSA Z259.12-16

Net weight : 3.2 oz. / 90 g

Zinc Plated

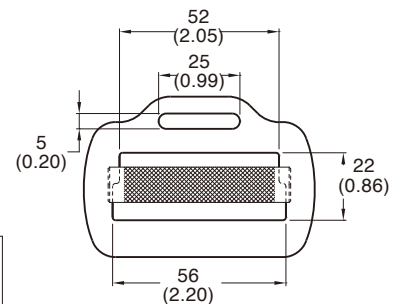

mm (inch)

N-4797
Extra Lock QR Buckle

Sheet steel, heat treated
 Min. Breaking Load : 4000 lbs / 18 kN
 Meets :
 ● ANSI Z359.12-2019
 ● CSA Z259.12-16
 Net weight : 5.5 oz. / 156 g
Patent US 9578929

Zinc Plated

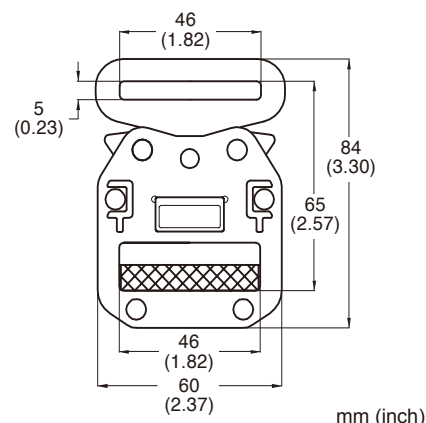

N-479
QRA Buckle
(Adjust Buckle)

Sheet steel, heat treated
 Min. Breaking Load : 4000 lbs / 18 kN
 Meets :
 ● ANSI Z359.12-2019
 ● CSA Z259.12-16
 Net weight : 4.3 oz. / 122 g
Patent US 10609989

Zinc Plated

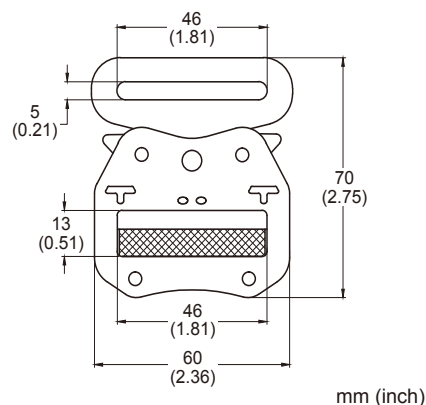

N-4793
QRA Buckle
(Adjust Buckle)

Sheet steel, heat treated
 Min. Breaking load : 4000 lbs / 18 kN
 Meets :
 ● ANSI Z359.12-2019
 ● CSA Z259.12-16
 Net weight : 4.5 oz. / 127 g
Patent US 10609989

Zinc Plated

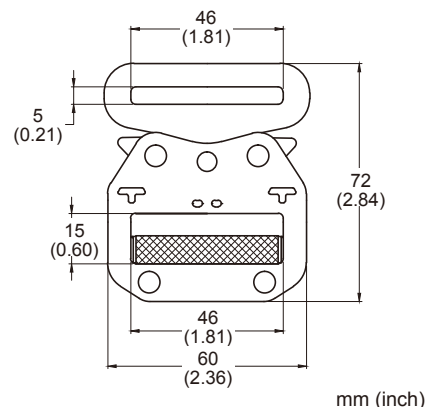

N-438
Safety Buckle
with bayonet catch

Forged steel, heat treated
 Min. Breaking load : 5000 lbs / 23 kN
 Net weight : 6.3 oz. / 180 g

Zinc Plated

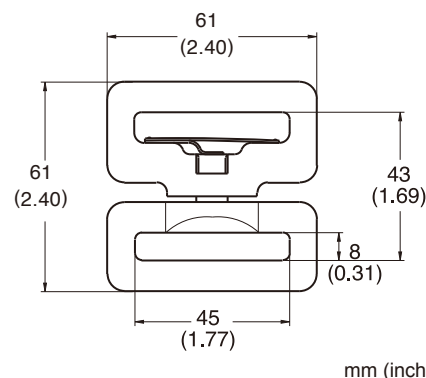

N-439X
Stamped Tongue Buckle, 1-7/8"

Sheet steel, heat treated
 Min. Breaking load : 4000 lbs / 18 kN
 Meets :
 ● ANSI Z359.12-2019
 ● CSA Z259.12-16
 Net weight : 2.7 oz. / 78 g

Zinc Plated

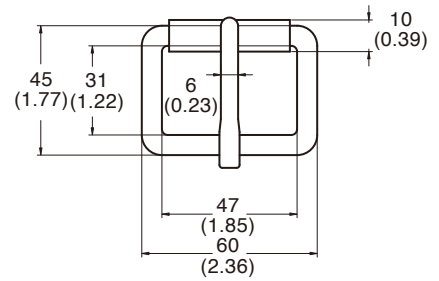

mm (inch)

N-439
Tongue Buckle, 1-7/8"

Forged steel, heat treated
 Min. Breaking load : 4000 lbs / 18 kN
 Meets :
 ● ANSI Z359.12-2019
 ● CSA Z259.12-16
 Net weight : 3.5 oz. / 99 g

Zinc Plated

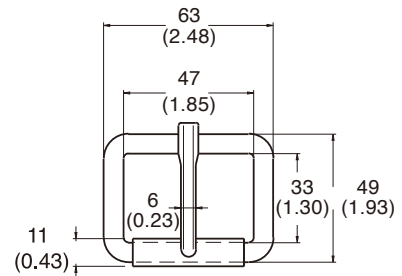

mm (inch)

N-441
Tongue Buckle, 2"

Forged steel, heat treated
 Min. Breaking load : 4000 lbs / 18 kN
 Meets :
 ● ANSI Z359.12-2019
 ● CSA Z259.12-16
 Net weight : 3.3 oz. / 96 g

Zinc Plated

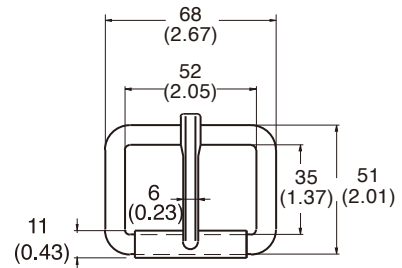

mm (inch)

N-440
Twin Tongue Buckle, 2"

Forged steel, heat treated
 Min. Breaking load : 4000 lbs / 18 kN
 Meets :
 ● ANSI Z359.12-2019
 ● CSA Z259.12-16
 Net weight : 4.0 oz. / 115 g

Zinc Plated

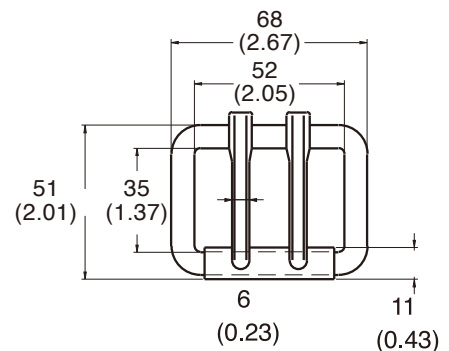

mm (inch)



**N-DE244-0
Dielectric Carabiner**

Alloy steel, heat treated
 Min. Breaking load : 5000 lbs / 23 kN
 Meets:
 ● EN 362 : 2004
 Minimum 4kV Dielectric Resistance
 Net weight : 5.7 oz. / 163 g
Patent Pending

New

Plastic Over Molded

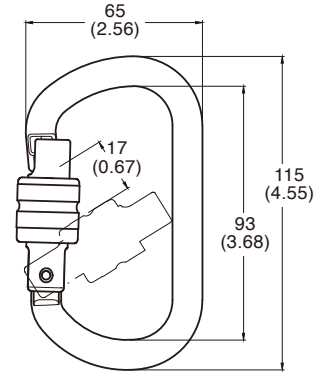

mm (inch)

**N-DE360
Dielectric ANSI Rope Snap Hook**

Sheet steel, heat treated
 100% proof loaded to 3600 lbs / 16kN
 Min. Breaking load : 5000 lbs / 23 kN
 Meets :
 ● ANSI Z359.12-2019
 ● CSA Z259.12-16
 ● EN 362 : 2004
 Minimum 9kV Dielectric Resistance
 Net weight : 14.2 oz. / 404 g
Patent US 9885379

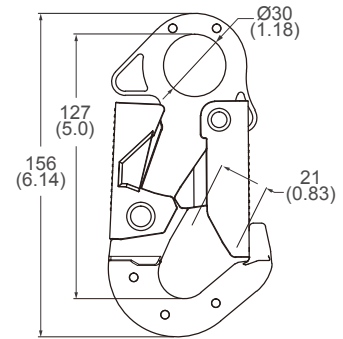

mm (inch)

**N-DE301
Dielectric Rebar Hook**

Forged steel, heat treated
 Min. Breaking load : 5000 lbs / 23 kN
 Meets :
 ● EN362 : 2004
 Minimum 9kV Dielectric Resistance
 Net weight : 19.2 oz. / 548g
Patent US 9199105

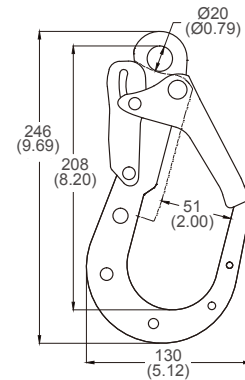

mm (inch)

**N-DE300
Dielectric Snap Hook**

Sheet steel, heat treated
 Min. Breaking load : 5000 lbs / 23 kN
 Meets :
 ● EN362 : 2004
 Minimum 9kV Dielectric Resistance
 Net weight : 9.2 oz. / 264 g
Patent US 9199105

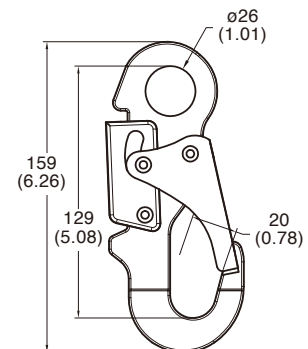

mm (inch)

Plastic Over Molded

**N-DE001
Dielectric D-Ring**

Sheet steel, heat treated
100% proof loaded to 3600lbs / 16 kN
Min. Breaking load : 5000 lbs / 23 kN

Meets :

- ANSI Z359.12-2019
- CSA Z259.12-16

Minimum 9kV Dielectric Resistance

Net weight : 5.8 oz. / 164 g

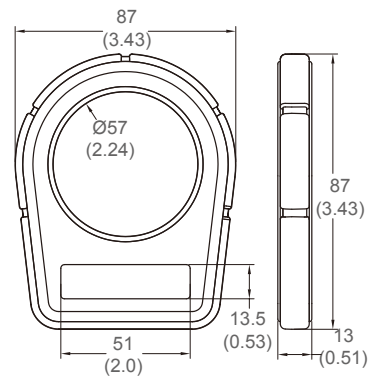

mm (inch)

**N-DE002
Dielectric Bent D-Ring**

Sheet steel, heat treated
100% proof loaded to 3600lbs / 16 kN
Min. Breaking load : 5000 lbs / 23 kN

Meets :

- ANSI Z359.12-2019
- CSA Z259.12-16

Minimum 9kV Dielectric Resistance

Net weight : 6.1 oz. / 176 g

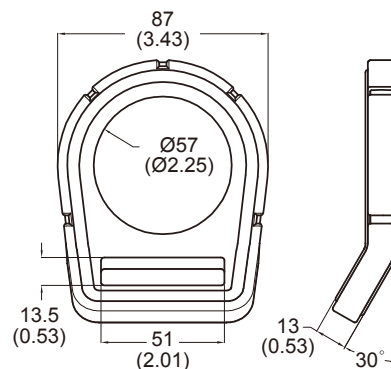

mm (inch)

**N-DE403
Dielectric D-Ring**

Sheet steel, heat treated
100% proof loaded to 3600 lbs / 16kN
Min. Breaking load : 5000 lbs / 23 kN

Meets :

- ANSI Z359.12-2019
- CSA Z259.12-16

Minimum 4kV Dielectric Resistance

Net weight : 2.7 oz. / 77 g

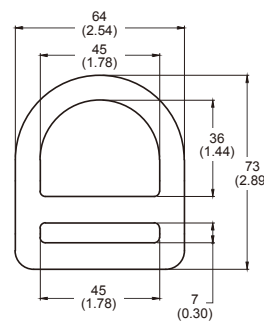

mm (inch)

**N-DE403B
Dielectric Bent D-Ring**

Sheet steel, heat treated
100% proof loaded to 3600 lbs / 16kN
Min. Breaking load : 5000 lbs / 23 kN

Meets :

- ANSI Z359.12-2019
- CSA Z259.12-16

Minimum 4kV Dielectric Resistance

Net weight : 2.6 oz. / 76 g

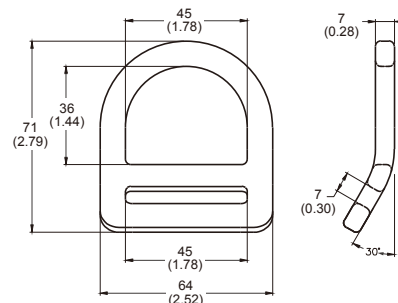

mm (inch)

N-DE415
Dielectric D-Ring

Sheet steel, heat treated
 100% proof loaded to 3600 lbs / 16kN
 Min. Breaking load : 5000 lbs / 23 kN
 Meets :
 ● ANSI Z359.12-2019
 ● CSA Z259.12-16
 Minimum 4kV Dielectric Resistance
 Net weight : 5.3 oz. / 152 g

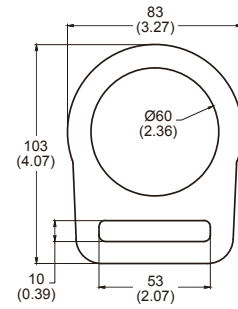

mm (inch)

N-DE415B
Dielectric Bent D-Ring

Sheet steel, heat treated
 100% proof loaded to 3600 lbs / 16kN
 Min. Breaking load : 5000 lbs / 23 kN
 Meets :
 ● ANSI Z359.12-2019
 ● CSA Z259.12-16
 Minimum 4kV Dielectric Resistance
 Net weight : 5.2 oz. / 147 g

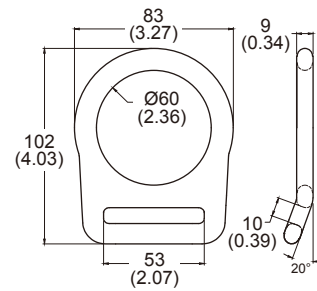

mm (inch)

N-DE460
Dielectric D-Ring

Sheet steel, heat treated
 100% proof loaded to 3600 lbs / 16kN
 Min. Breaking load : 5000 lbs / 23 kN
 Meets :
 ● ANSI Z359.12-2019
 ● CSA Z259.12-16
 Minimum 4kV Dielectric Resistance
 Net weight : 7.0 oz. / 200 g

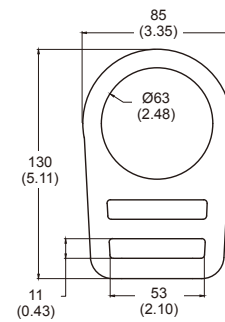

mm (inch)

N-DE460B
Dielectric Bent D-Ring

Sheet steel, heat treated
 100% proof loaded to 3600 lbs / 16kN
 Min. Breaking load : 5000 lbs / 23 kN
 Meets :
 ● ANSI Z359.12-2019
 ● CSA Z259.12-16
 Minimum 4kV Dielectric Resistance
 Net weight : 7.0 oz. / 200 g

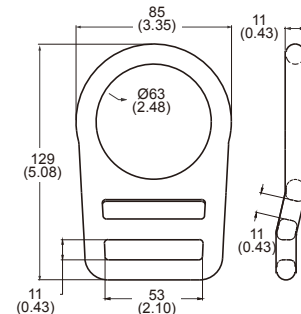

mm (inch)

N-DE007
Dielectric Quick Release Buckle

Sheet steel, heat treated

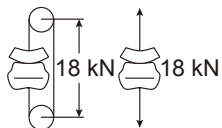

Minimum 9kV Dielectric Resistance

Net weight : 4.5 oz. / 128 g

Patent US 10010141

Plastic Over Molded

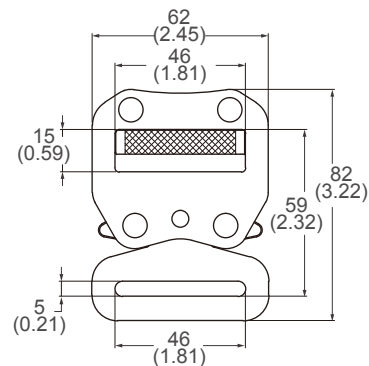

mm (inch)

N-DE009
Dielectric Adjuster

Sheet steel, heat treated

Min. Breaking load : 4000 lbs / 18 kN

Meets :

- ANSI Z359.12-2019
- CSA Z259.12-16

Minimum 9kV Dielectric Resistance

Net weight : 2.98 oz. / 85g

Patent Pending

Plastic Over Molded

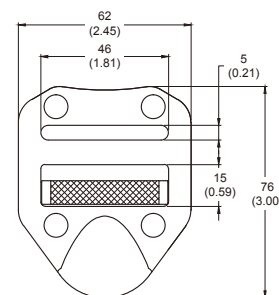

mm (inch)

N-DE518
Dielectric Alum D Ring

Aluminum alloy

Min. Breaking load : 5000 lbs / 23 kN

Meets:

- ANSI Z359.12-2019
- CSA Z259.12-16

Minimum 4kV Dielectric Resistance

Net weight : 2.9 oz. / 84 g

New

Plastic Over Molded

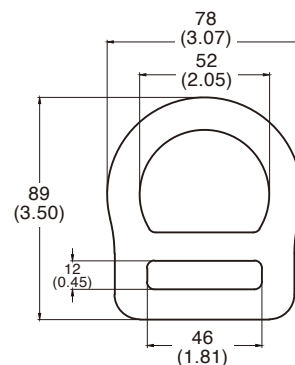

mm (inch)

N-DE529
Dielectric Bent Alum D Ring

Aluminum alloy

Min. Breaking load : 5000 lbs / 23 kN

Meets:

- ANSI Z359.12-2019
- CSA Z259.12-16

Minimum 4kV Dielectric Resistance

Net weight : 4.2 oz. / 120 g

New

Plastic Over Molded

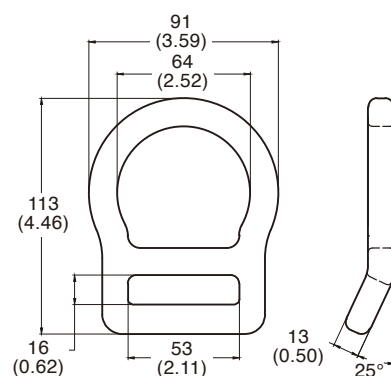

mm (inch)

**N-DE483
Dielectric O-Ring**

Sheet steel, heat treated
 100% proof loaded to 3600 lbs / 16kN
 Min. Breaking load : 5000 lbs / 23 kN
 Meets :
 ● ANSI Z359.12-2019
 ● CSA Z259.12-16
 Minimum 4kV Dielectric Resistance
 Net weight : 3.6 oz. / 103 g

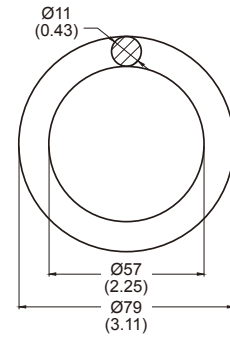

Plastic Over Molded

mm (inch)

**N-DE005
Dielectric Quick Buckle**

Sheet steel, heat treated
 Min. Breaking load : 4000 lbs / 18 kN
 Meets :
 ● ANSI Z359.12-2019
 ● CSA Z259.12-16
 Minimum 9kV Dielectric Resistance
 Net weight : 1.6 oz. / 45 g

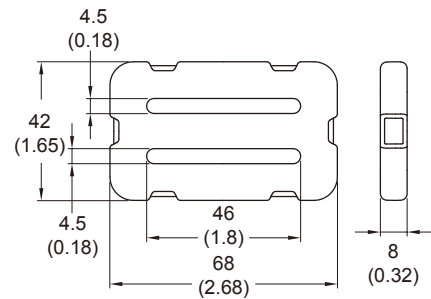

Plastic Over Molded

mm (inch)

**N-DE006
Dielectric Quick Buckle**

Sheet steel, heat treated
 Min. Breaking load : 4000 lbs / 18 kN
 Meets :
 ● ANSI Z359.12-2019
 ● CSA Z259.12-16
 Minimum 9kV Dielectric Resistance
 Net weight : 2.2 oz. / 61 g

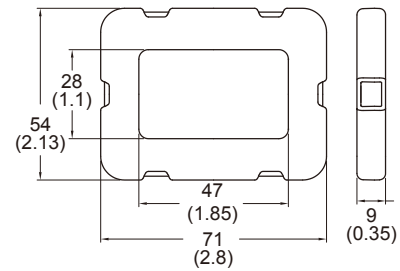

Plastic Over Molded

mm (inch)

**N-DE420
Dielectric Quick Buckle**

Sheet steel, heat treated
 Min. Breaking load : 4000 lbs / 18 kN
 Meets :
 ● ANSI Z359.12-2019
 ● CSA Z259.12-16
 Minimum 4kV Dielectric Resistance
 Net weight : 1.3 oz. / 36 g

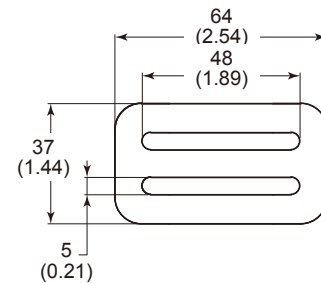

Plastic Over Molded

mm (inch)

N-DE422
Dielectric Quick Buckle

Sheet steel, heat treated
 Min. Breaking load : 4000 lbs / 18 kN
 Meets :
 ● ANSI Z359.12-2019
 ● CSA Z259.12-16
 Minimum 4kV Dielectric Resistance
 Net weight : 1.1 oz. / 32 g

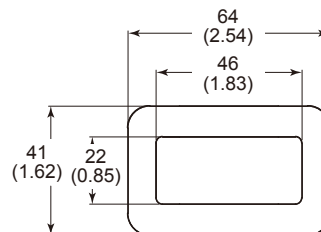

Plastic Over Molded

mm (inch)

N-DE448
Dielectric Quick Buckle

Sheet steel, heat treated
 Min. Breaking load : 4000 lbs / 18 kN
 Meets :
 ● ANSI Z359.12-2019
 ● CSA Z259.12-16
 Minimum 4kV Dielectric Resistance
 Net weight : 2.5 oz. / 70 g

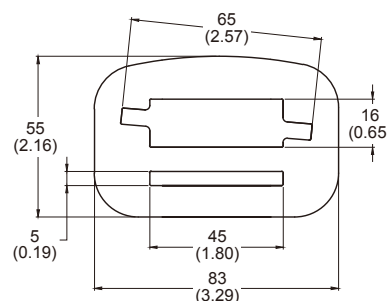

Plastic Over Molded

mm (inch)

N-DE4207
Dielectric Quick Buckle

Sheet steel, heat treated
 Min. Breaking load : 4000 lbs / 18 kN
 Meets :
 ● ANSI Z359.12-2019
 ● CSA Z259.12-16
 Minimum 4kV Dielectric Resistance
 Net weight : 1.3 oz. / 38 g

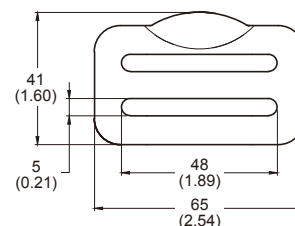

Plastic Over Molded

mm (inch)

N-DE452
Dielectric Quick Buckle

Sheet steel, heat treated
 Min. Breaking load: 4000 lbs / 18 kN
 Meets :
 ● ANSI Z359.12-2019
 ● CSA Z259.12-16
 Minimum 4kV Dielectric Resistance
 Net weight : 1.3 oz. / 35.7g

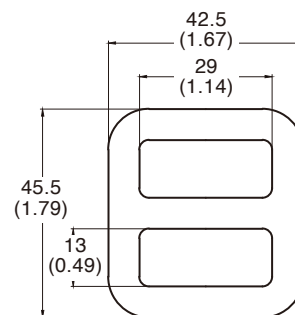

Plastic Over Molded

mm (inch)

New

N-5271T

Aluminum Rebar Hook 3600 LBS gate/Transverse Load

Forged aluminum alloy

100% proof loaded to 3600 lbs / 16kN

Min. Breaking load : 5000 lbs / 23 kN

Meets:

- ANSI Z359.12-2019
- CSA Z259.12-16
- EN 362 : 2004

Net weight : 22.3 oz. / 637 g

Anodized

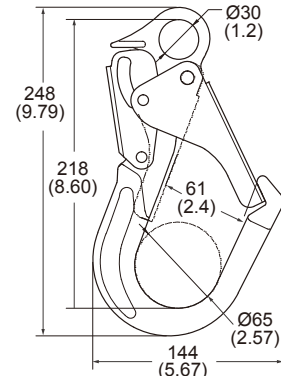

mm (inch)

N-5275T

Indicator Swivel Alum Rebar Hook 3600 LBS gate / Transverse Load

Forged aluminum alloy

100% proof loaded to 3600 lbs / 16 kN

Min. Breaking load : 5000 lbs / 23 kN

Meets :

- ANSI Z359.12-2019
- CSA Z259.12-16
- EN 362 : 2004

Net weigh : 24.68oz. / 705 g

Anodized

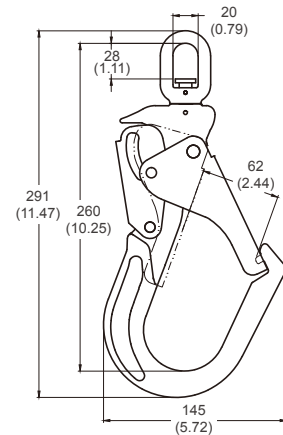

mm (inch)

N-5268

Aluminum Step Bolt Hook 3600 LBS gate strength

Specifically designed for step bolts 16 mm diameter

Forged aluminum alloy

100% proof loaded to 3600 lbs / 16 kN

Min. Breaking load : 5000 lbs / 23 kN

Meets :

- ANSI Z359.12-2019
- CSA Z259.12-16
- EN 362 : 2004

Net weight : 14.5 oz. / 414 g

Anodized

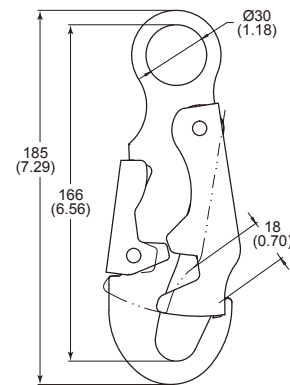

mm (inch)

N-5261

Aluminum Snap Hook 3600 LBS gate strength

Forged aluminum alloy

100% proof loaded to 3600 lbs / 16 kN

Min. Breaking load : 5000 lbs / 23 kN

Meets :

- ANSI Z359.12-2019
- CSA Z259.12-16
- EN 362 : 2004

Net weight : 8.7 oz. / 247 g

Anodized

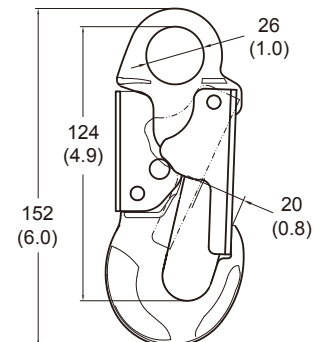

mm (inch)

N-5265
Alum Indicator Swivel Snap Hook
3600 LBS gate strength

Forged aluminum alloy
 100% proof loaded to 3600 lbs / 16 kN
 Min. Breaking load : 5000 lbs / 23 kN
 Meets :
 ● ANSI Z359.12-2019
 ● CSA Z259.12-16
 Net weight : 10.6 oz. / 304 g

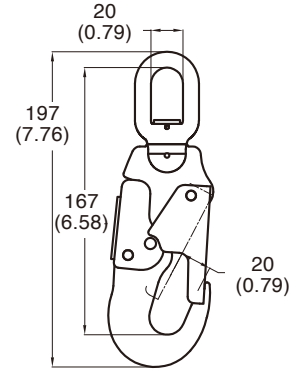

mm (inch)

N-5265 / 0
Aluminum Swivel Snap Hook
3600 LBS gate strength

Forged aluminum alloy
 100% proof loaded to 3600 lbs / 16 kN
 Min. Breaking load : 5000 lbs / 23 kN
 Meets :
 ● ANSI Z359.12-2019
 ● CSA Z259.12-16
 Net weight : 10.5 oz. / 300 g

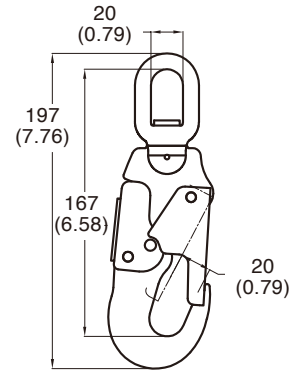

mm (inch)

N-5246
Aluminum Snap Hook

Forged aluminum alloy
 Min. Breaking load : 5000 lbs / 23 kN
 Meets :
 ● EN 362 : 2004
 Net weight : 6.0 oz. / 169 g

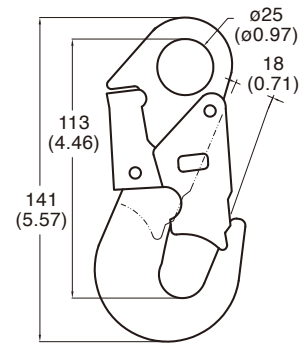

mm (inch)

N-5248
Aluminum Snap Hook

Forged aluminum alloy
 Min. Breaking load : 5000 lbs / 23 kN
 Meets :
 ● EN 362 : 2004
 Net weight : 8.5 oz. / 244 g

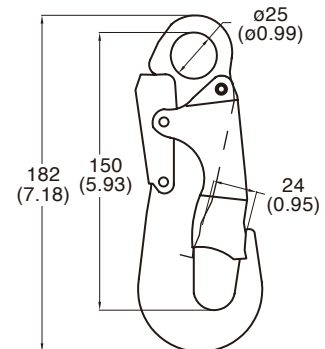

mm (inch)

Anodized

N-331 SRD Attachment Bracket

Forged steel / aluminum alloy
Net weight : 5.6 oz. / 159 g

Patent US 10065057

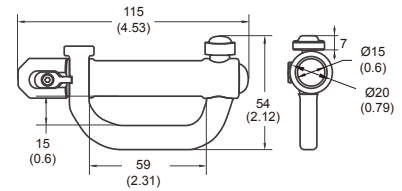

mm (inch)

N-339 SRD Attachment Bracket

Forged steel
Net weight : 6.0 oz. / 170 g

Patent Pending

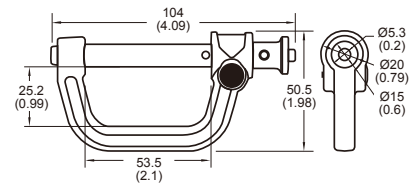

mm (inch)

N-502 Aluminum Snap Hook

Forged aluminum alloy
Min. Breaking load : 5000 lbs / 23 kN
Meets :
● EN 362 : 2004
Net weight : 6.7 oz. / 189 g



N-502-1
Blue

N-502-2
Green

N-502-3
Red

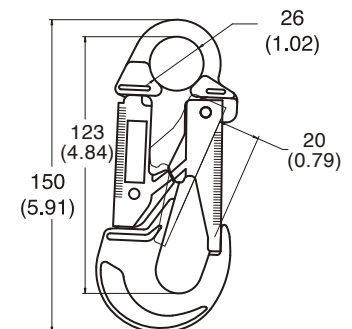

mm (inch)

N-504 Aluminum Snap Hook

Forged aluminum alloy
Min. Breaking load : 5000 lbs / 23 kN
Meets :
● EN 362 : 2004
Net weight : 5.5 oz. / 158 g

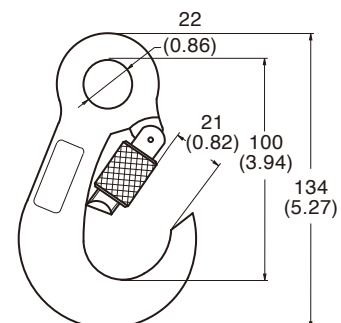

mm (inch)

Anodized

**N-500
Aluminum Rebar Hook**

Forged aluminum alloy
 Min. Breaking load : 5000 lbs / 23 kN
 Meets :
 ● EN 362 : 2004
 Net weight : 18 oz. / 520 g

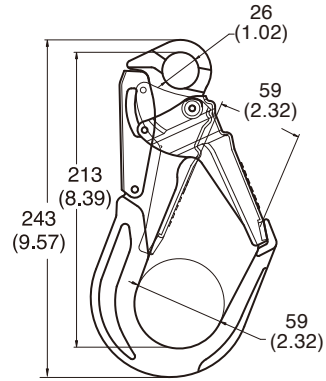

mm (inch)

Anodized

**N-501
Aluminum Rebar Hook**

Forged aluminum alloy
 Min. Breaking load : 5000 lbs / 23 kN
 Meets :
 ● EN 362 : 2004
 Net weight : 16.2 oz. / 460 g

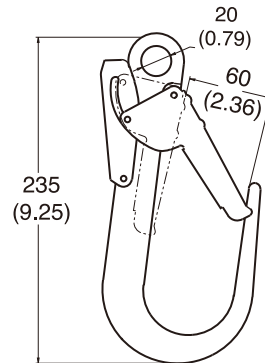

mm (inch)

Anodized

**N-50130
Aluminum Rebar Hook**

Forged aluminum alloy
 Min. Breaking load : 5000 lbs / 23 kN
 Meets :
 ● EN 362 : 2004
 Net weight : 16.8 oz. / 480 g

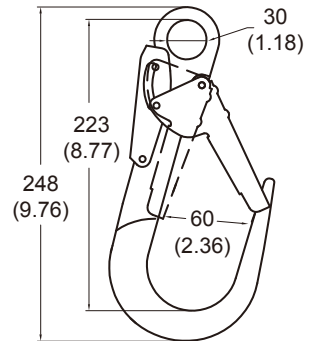

mm (inch)

Anodized

**N-501110
Aluminum Huge Rebar Hook**

Forged aluminum alloy
 Min. Breaking load : 5000 lbs / 23 kN
 Meets :
 ● EN 362 : 2004
 Net weight : 32.8 oz. / 930 g

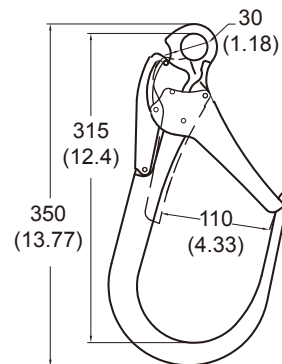

mm (inch)

Anodized

N-50110X Aluminum Huge Rebar Hook

Forged aluminum alloy
 Min. Breaking load : 4500 lbs / 20 kN
 Meets :
 ● EN 362 : 2004
 Net weight : 32.8 oz. / 930 g

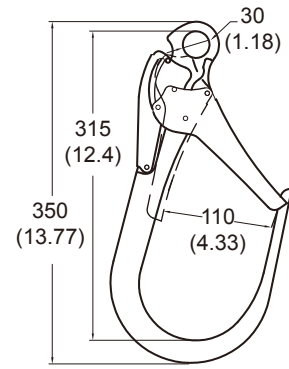

mm (inch)

Anodized

N-5015 Aluminum Indicator Swivel Rebar Hook

Forged aluminum alloy
 Min. Breaking load : 5000 lbs / 23 kN
 Meets :
 ● EN 362 : 2004
 Net weight : 18.66 oz. / 529 g

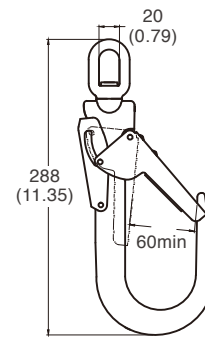

mm (inch)

Anodized

New

N-5015 / 0 Aluminum Swivel Rebar Hook

Forged aluminum alloy
 Min. Breaking load : 5000 lbs / 23 kN
 Meets :
 ● EN 362 : 2004
 Net weight : 18.66 oz. / 529 g

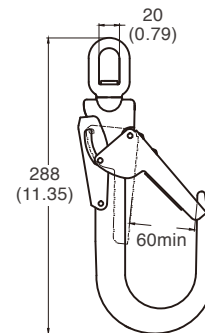

mm (inch)

Anodized

New

N-5018 Aluminum Rebar Hook

Forged aluminum alloy
 Min. Breaking load : 5000 lbs / 23 kN
 Meets :
 ● EN 362 : 2004
 Net weight : 9.2 oz. / 260 g

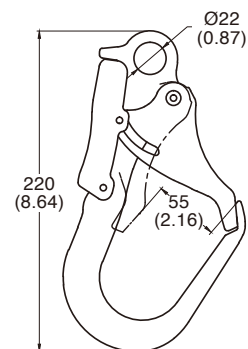

mm (inch)

Anodized

New

**N-503
Aluminum Snap Hook**

Forged aluminum alloy
 Min. Breaking load : 5000 lbs / 23 kN
 Meets EN 362 : 2004
 Net weight : 4.5 oz. / 130 g

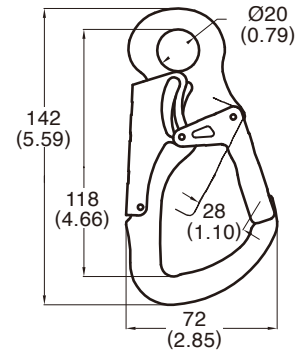

mm (inch)

Anodized

**N-5032
Aluminum Snap Hook**

Forged aluminum alloy
 Mini. Breaking load : 5000 lbs / 23 kN
 Meets EN 362 : 2004
 Net weight : 4.6 oz. / 134 g

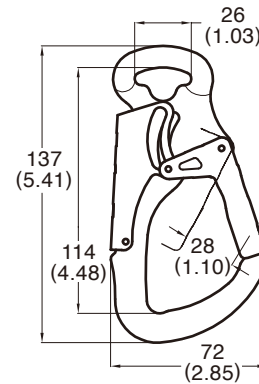

mm (inch)

Anodized

**N-5035
Aluminum Indicator Swivel
Snap Hook**

Forged aluminum alloy
 Min. Breaking load : 5000 lbs / 23 kN
 Meets EN 362 : 2004
 Net weight : 6.4 oz. / 184 g

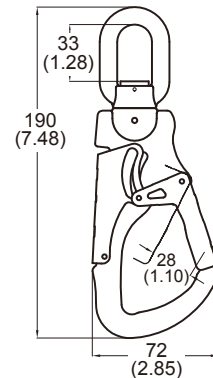

mm (inch)

Anodized

**N-5035 / 0
Aluminum Swivel Snap Hook**

Forged aluminum alloy
 Min. Breaking load : 5000 lbs / 23 kN
 Meets EN 362 : 2004
 Net weight : 6.3 oz. / 180 g

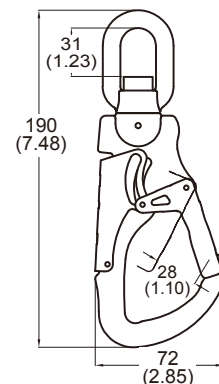

mm (inch)

Anodized

N-528 Aluminum D-Ring

Forged aluminum alloy
 100% proof loaded to 3600 lbs / 16 kN
 Min. Breaking load : 5000 lbs / 23 kN
 Meets :
 ● ANSI Z359.12-2019
 ● CSA Z259.12-16
 Net weight : 2.6 oz. / 75 g

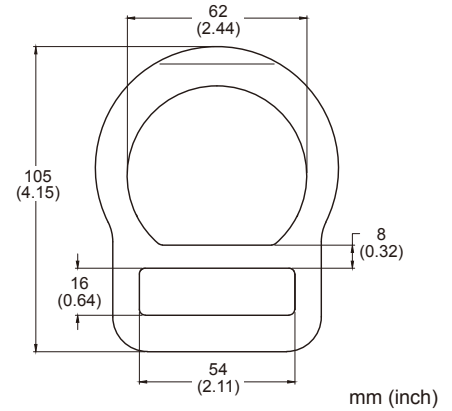

Anodized

N-529 Aluminum Bent D-Ring

Forged aluminum alloy
 100% proof loaded to 3600 lbs / 16 kN
 Min. Breaking load : 5000 lbs / 23 kN
 Meets :
 ● ANSI Z359.12-2019
 ● CSA Z259.12-16
 Net weight : 2.8 oz. / 78 g

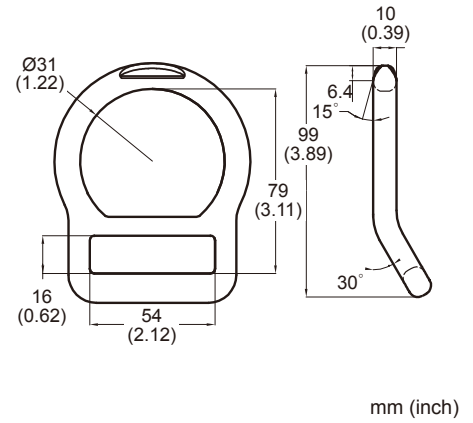

Anodized

N-528A Alum D-Ring-5M Middle Bar

Forged aluminum alloy
 100% proof loaded to 3600 lbs / 16kN
 Min. Breaking load : 5000 lbs / 23 kN
 Meets :
 ● ANSI Z359.12-2019
 ● CSA Z259.12-16
 Net weight : 3.3 oz. / 94 g

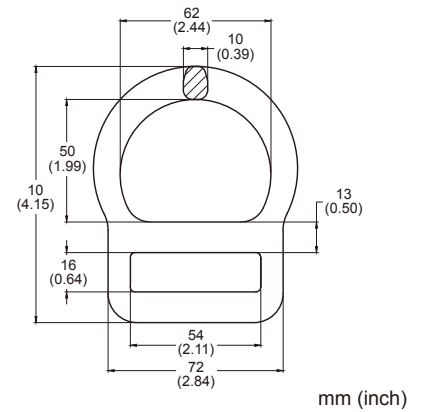

Anodized

N-529A Alum Bent D-Ring-5M Middle Bar

Forged aluminum alloy
 100% proof loaded to 3600 lbs / 16kN
 Min. Breaking load : 5000 lbs / 23 kN
 Meets :
 ● ANSI Z359.12-2019
 ● CSA Z259.12-16
 Net weight : 3.3 oz. / 94 g

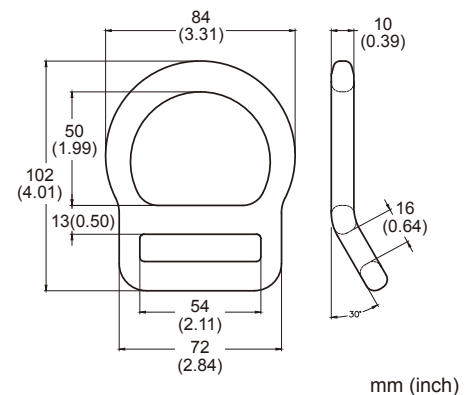

Anodized

**N-518
Aluminum D-Ring**

Forged aluminum alloy
 100% proof loaded to 3600 lbs / 16 kN
 Min. Breaking load : 5000 lbs / 23 kN
 Net weight : 2.7 oz. / 76 g

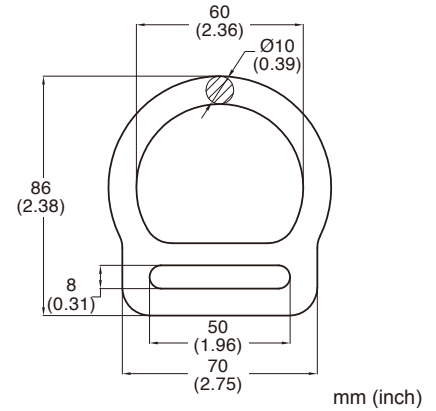

Anodized

**N-519
Aluminum Bent D-Ring**

Forged aluminum alloy
 100% proof loaded to 3600 lbs / 16 kN
 Min. Breaking load : 5000 lbs / 23 kN
 Net weight : 1.8 oz. / 74 g

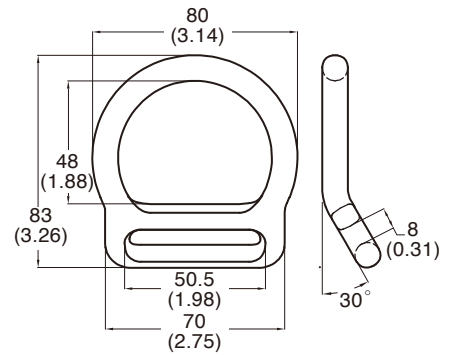

Anodized

**N-5416
Aluminum D-Ring**

Forged aluminum alloy
 100% proof loaded to 3600 lbs / 16 kN
 Min. Breaking load : 5000 lbs / 23 kN
 Meets :
 ● ANSI Z359.12-2019
 ● CSA Z259.12-16
 Net weight : 2.9 oz. / 83 g

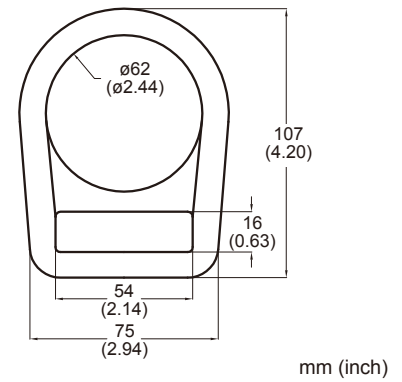

Anodized

**N-540
Aluminum D-Ring**

Forged aluminum alloy
 100% proof loaded to 3600 lbs / 16 kN
 Min. Breaking load : 5000 lbs / 23 kN
 Meets :
 ● ANSI Z359.12-2019
 ● CSA Z259.12-16
 Net weight : 4.0 oz. / 114 g

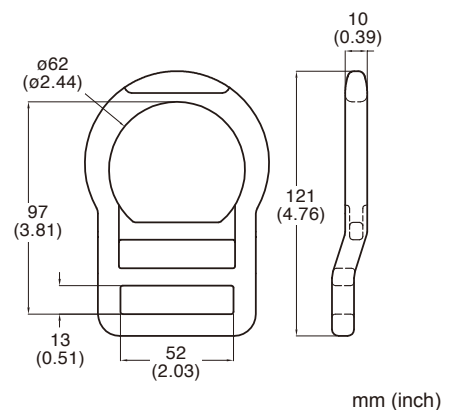

Anodized

N-5203 Aluminum D-Ring

Forged aluminum alloy
 100% proof loaded to 3600 lbs / 16 kN
 Min. Breaking load : 5000 lbs / 23 kN
 Meets :
 ● ANSI Z359.12-2019
 ● CSA Z259.12-16
 Net weight : 2.2 oz. / 62 g

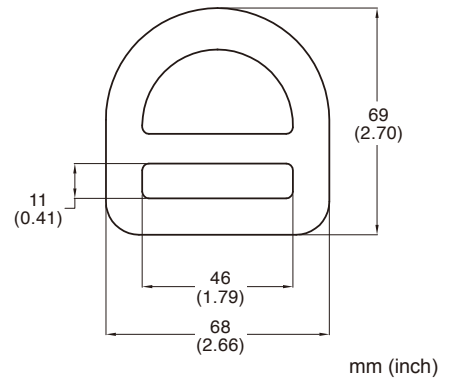

Anodized

N-5204 Aluminum Bent D-Ring

Forged aluminum alloy
 100% proof loaded to 3600 lbs / 16 kN
 Min. Breaking load : 5000 lbs / 23 kN
 Meets :
 ● ANSI Z359.12-2019
 ● CSA Z259.12-16
 Net weight : 1.9 oz. / 53 g

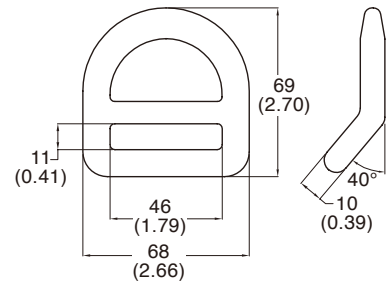

Anodized

N-507 Aluminum D-Ring

Forged aluminum alloy
 Min. Breaking load : 4000 lbs / 18 kN
 Net weight : 3.7 oz. / 106 g

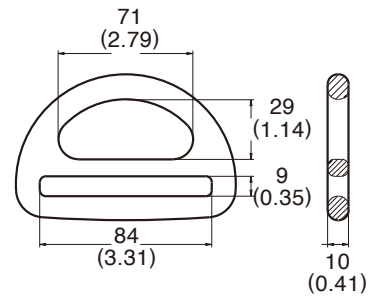

Anodized

N-512 Aluminum D-Ring

Forged aluminum alloy
 Min. Breaking load : 4000 lbs / 18 kN
 Net weight : 1.6 oz. / 44 g

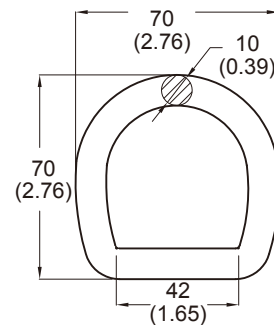

Anodized

**N-5407
Aluminum D-Ring**

Forged aluminum alloy
 100% proof loaded to 3600 lbs / 16 kN
 Min. Breaking load : 5000 lbs / 23 kN
 Meets :
 ● ANSI Z359.12-2019
 ● CSA Z259.12-16
 Net weight : 2.3 oz. / 65 g

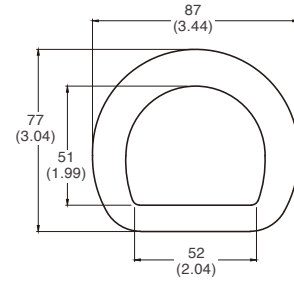

mm (inch)

Anodized

**N-5407B
Aluminum Bent D-Ring**

Forged aluminum alloy
 100% proof loaded to 3600 lbs / 16 kN
 Min. Breaking load : 5000 lbs / 23 kN
 Meets :
 ● ANSI Z359.12-2019
 ● CSA Z259.12-16
 Net weight : 2.2 oz. / 64 g

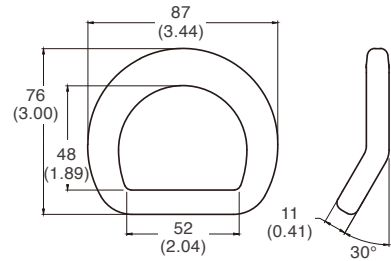

mm (inch)

Anodized

**N-5019
Aluminum Quick Buckle**

Sheet aluminum alloy
 Min. Breaking load : 2000 lbs / 9 kN
 Net weight : 0.3 oz. / 8g

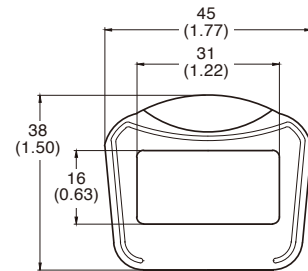

mm (inch)

Anodized

New

**N-5020
Aluminum Quick Buckle**

Sheet aluminum alloy
 Min. Breaking load: 2000 lbs / 9 kN
 Net weight: 0.2 oz./ 5 g

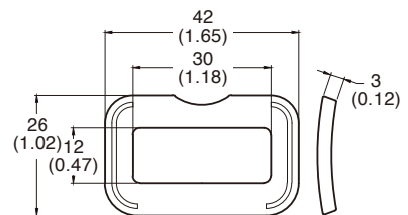

mm (inch)

Anodized

New

N-5719 Aluminum Quick Buckle

Sheet aluminum alloy
 Min. Breaking load : 2000 lbs / 9 kN
 Net weight : 0.2 oz. / 7 g

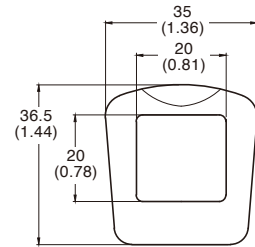

New

Anodized

mm (inch)

N-5721 Aluminum Quick Buckle

Sheet aluminum alloy
 Min. Breaking load : 2000 lbs / 9 kN
 Net weight : 0.2 oz. / 5 g

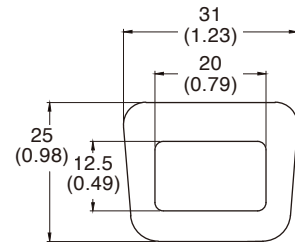

New

Anodized

mm (inch)

N-5720 Aluminum Quick Buckle

Forged aluminum alloy
 Min. Breaking load : 2000 lbs / 9 kN
 Net weight : 0.39 oz. / 11 g

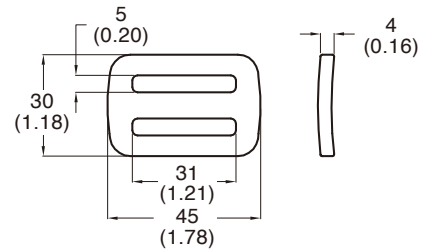

Anodized

mm (inch)

N-5722 Aluminum Quick Buckle

Forged aluminum alloy
 Min. Breaking load : 2000 lbs / 9 kN
 Net weight : 0.35 oz. / 10 g

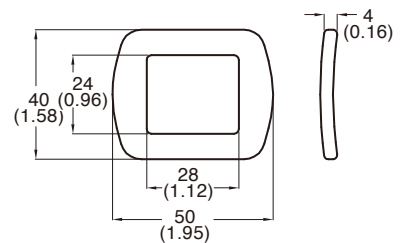

Anodized

mm (inch)

**N-5740
Aluminum Quick Buckle**

Forged aluminum alloy
 Min. Breaking load : 2000 lbs / 9 kN
 Net weight : 0.46 oz. / 13 g

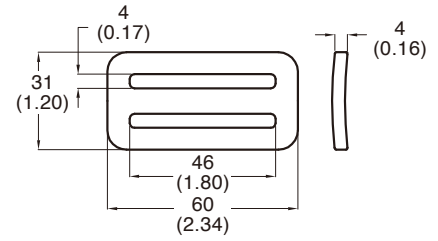

Anodized

mm (inch)

**N-5741
Aluminum Quick Buckle**

Forged aluminum alloy
 Min. Breaking load : 3400 lbs / 15 kN
 Meets :
 ● ANSI Z359.12-2019
 ● CSA Z259.12-16
 Net weight : 0.49 oz. / 14 g

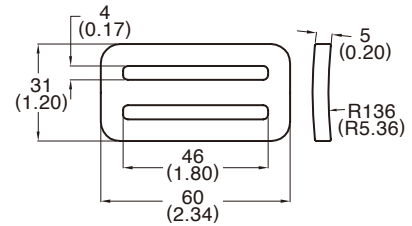

Anodized

mm (inch)

**N-5742
Aluminum Quick Buckle**

Forged aluminum alloy
 Min. Breaking load : 3400 lbs / 15 kN
 Meets :
 ● ANSI Z359.12-2019
 ● CSA Z259.12-16
 Net weight : 0.42 oz. / 12 g

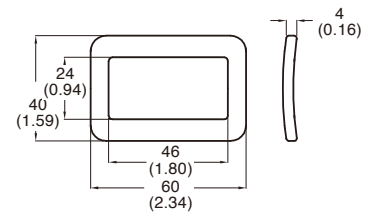

Anodized

mm (inch)

**N-5748
Aluminum Quick Buckle**

Forged aluminum alloy
 Min. Breaking load : 3400 lbs / 15 kN
 Meets :
 ● ANSI Z359.12-2019
 ● CSA Z259.12-16
 Net weight : 0.95 oz. / 27 g

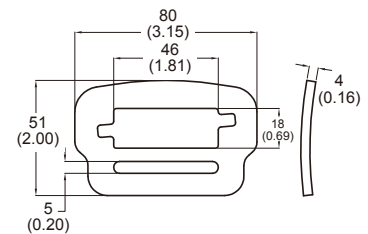

Anodized

mm (inch)

N-509 Aluminum Long Adjuster

Forged aluminum alloy
 Min. Breaking load : 2200 lbs / 11 kN
 Net weight : 2.0 oz. / 56 g

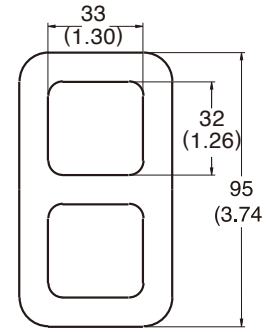

mm (inch)

Anodized

N-508 Aluminum Adjuster

Forged aluminum alloy
 Min. Breaking load : 4500 lbs / 20 kN
 Net weight : 1.3 oz. / 37 g

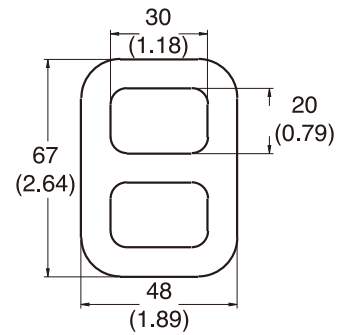

mm (inch)

Anodized

N-511 Aluminum Tongue Buckle with double tongue

Forged aluminum alloy
 Min. Breaking load : 4000 lbs / 18 kN
 Net weight : 2.0 oz. / 58 g

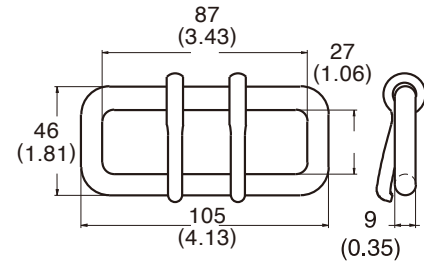
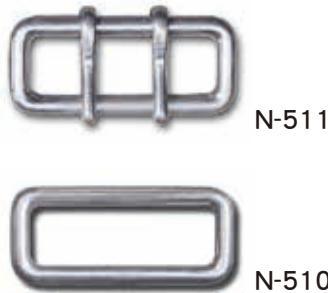

mm (inch)

N-510
 Aluminum Loop only.
 without double tongue Anodized

N-5439 Aluminum Tongue Buckle

Forged aluminum alloy
 Min. Breaking load : 4000 lbs / 18 kN
 Meets :
 ● ANSI Z359.12-2019
 ● CSA Z259.12-16
 Net weight : 2.3 oz. / 67 g

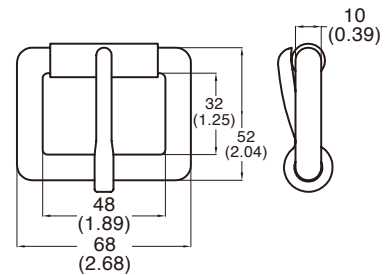

mm (inch)

Anodized

**N-5212
Aluminum Adjuster Buckle**

Forged aluminum alloy
 Min. Breaking load : 4000 lbs / 18 kN
 Meets :
 ● ANSI Z359.12-2019
 ● CSA Z259.12-16
 Net weight : 2.7 oz. / 76 g

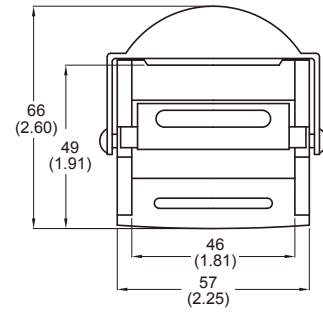

mm (inch)

Anodized

**N-533
Aluminum Adjuster Buckle**

Forged aluminum alloy
 Min. Breaking load : 4000 lbs / 18 kN
 Meets :
 ● ANSI Z359.12-2019
 ● CSA Z259.12-16
 Net weight : 1.9 oz. / 54 g

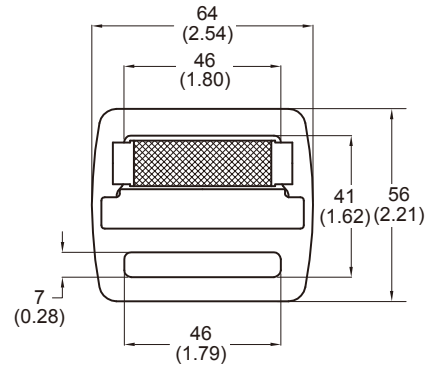

mm (inch)

Anodized

**N-51428 / N-51445 / N-51460
Aluminum O Ring**

Forged aluminum alloy
 100% proof loaded to 3600 lbs / 16kN
 Min. Breaking load : 5000 lbs / 23 kN
 Meets :
 ● ANSI Z359.12-2019
 ● CSA Z259.12-16

Art.No	Dimensions(mm)			Weight	
	A	B	C	(g)	(oz)
N-51428	ø12	52	28	38	1.3
N-51445	ø12	70	45	55	2.0
N-51460	ø10	80	60	50	1.8

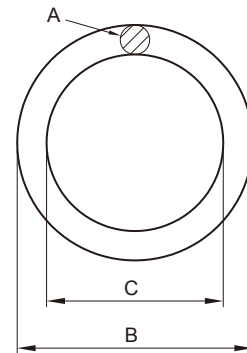

N-51428

N-51445

N-51460

Anodized

N-5877 Extra Lock Aluminum QR Buckle

Aluminum alloy

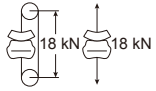

Meets :

- ANSI Z359.12-2019
- CSA Z259.12-16

Net weight : 4.6 oz. / 131 g

Patent US 9521882

Anodized

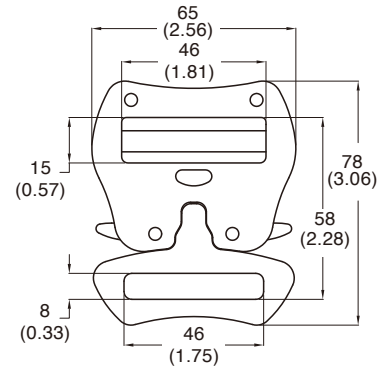

mm (inch)

N-5868 Aluminum QR Buckle

Aluminum alloy

Net weight : 1.82 oz. / 52 g

Anodized

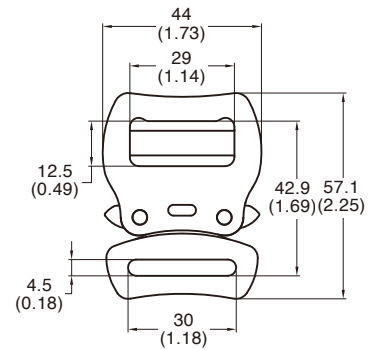

mm (inch)

N-5868T Aluminum QR Buckle

Aluminum alloy

Net weight : 2.14 oz. / 61 g

Anodized

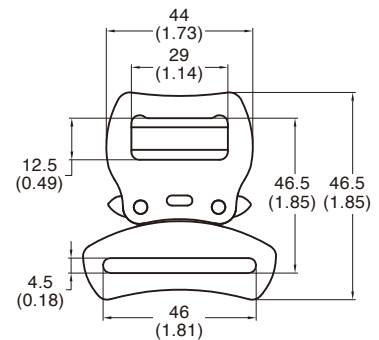

mm (inch)

N-5869T Aluminum QR Buckle

Aluminum alloy

Net weight : 2.45 oz. / 70 g

Anodized

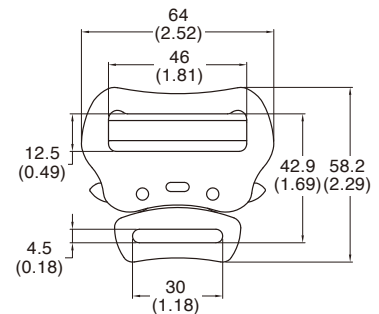

mm (inch)

**N-5869
Aluminum QR Buckle**

Aluminum alloy

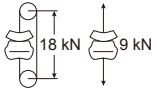

Net weight : 2.8 oz. / 79g

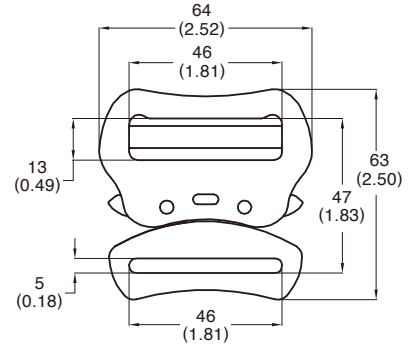

mm (inch)

Anodized

**N-5870A
Aluminum QR Buckle**

Forged aluminum alloy

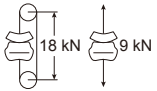

Net weight : 2.7 oz. / 76 g

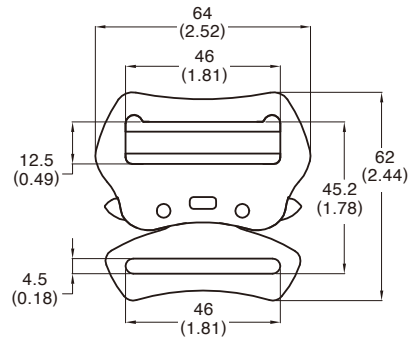

mm (inch)

Anodized

**N-5871
Aluminum QR Buckle**

Aluminum alloy

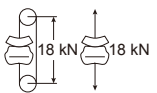

Meets :

- ANSI Z359.12-2019
- CSA Z259.12-16

Net weight : 3.2 oz. / 93 g

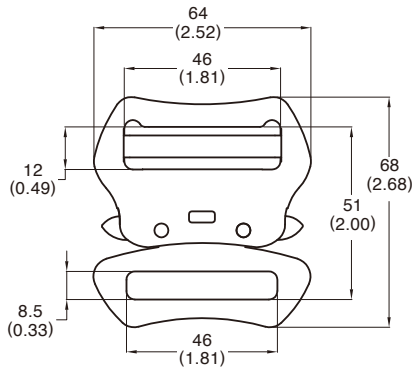

mm (inch)

Anodized

**N-479-S
QRA Buckle**

Stainless steel

Net weight : 4.4 oz. / 125 g

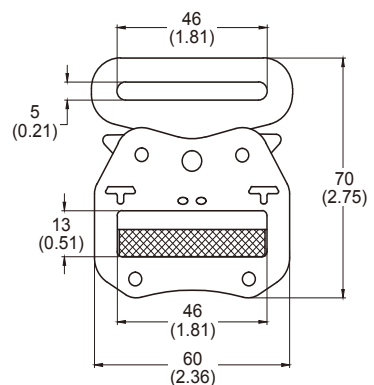

mm (inch)

Zinc Plated

N-5860

QRA Buckle

Forged aluminum alloy

Min. Breaking load : 4000 lbs / 18 kN

Meets :

- ANSI Z359.12-2019

- CSA Z259.12-16

Net weight : 5.3 oz. / 150 g

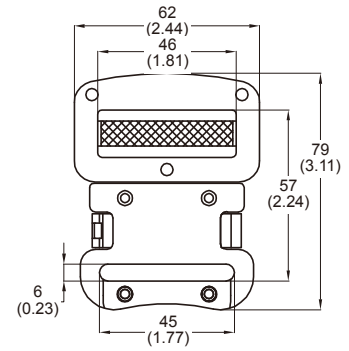

mm (inch)

Anodized

N-5861

QRA Buckle

Forged aluminum alloy

Min. Breaking load : 3372 lbs / 15 kN

Meets :

- ANSI Z359.12-2019

- CSA Z259.12-16

Net weight : 3.9 oz. / 110 g

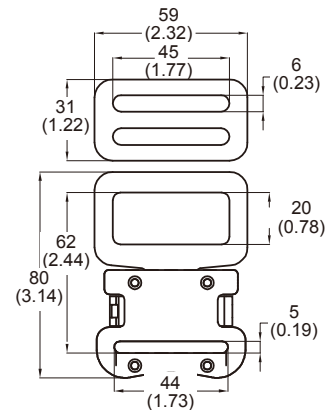

mm (inch)

Anodized

N-5862

QRA Buckle

Forged aluminum alloy

Min. Breaking Load : 4000 lbs / 18 kN

Meets :

- ANSI Z359.12-2019

- CSA Z259.12-16

Net weight : 3.5 oz. / 100 g

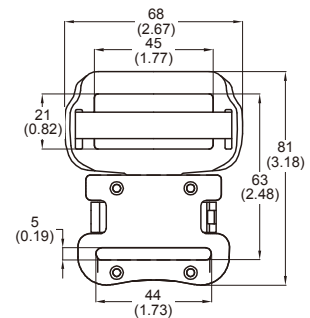

mm (inch)

Anodized

N-5867

QRA Buckle

Forged aluminum alloy

Min. Breaking load : 2000 lbs / 9 kN

Net weight : 3.6 oz. / 103 g

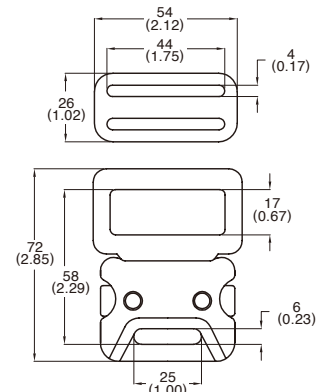

mm (inch)

Anodized

N-3591-S
Swivels - jaw to jaw

Stainless Steel, SUS 304
 Min Breaking load : 5000 lbs / 23 kN
 Net weight : 2.5 oz. / 74 g

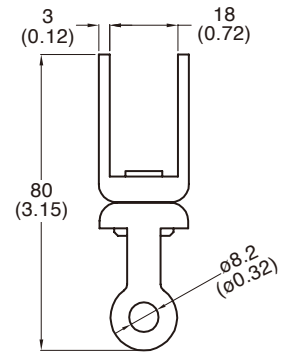

mm (inch)

Polished

N-904-S
Anchorage Connector (5 / 8")

Stainless steel
 Min. Breaking load : 5000 lbs / 23 kN
 Net weight : 22.7 oz. / 645 g

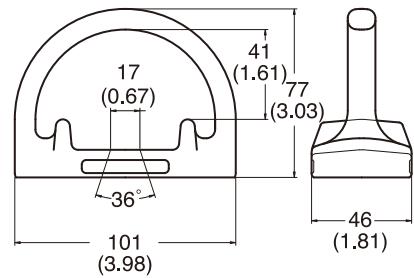

mm (inch)

Polished

N-430-S
D-Ring, with bar

Stainless steel, SUS 304
 Min. Breaking load : 3600 lbs / 16 kN
 Net weight : 3.1 oz. / 90 g

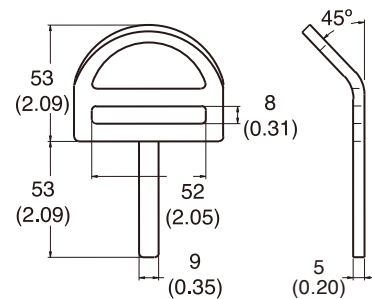

mm (inch)

Polished

N-403-S

D-Ring

Stainless steel, SUS 304

100% proof loaded to 3600 lbs / 16 kN

Min. Breaking load : 5000 lbs / 23 kN

Meets :

- ANSI Z359.12-2019
- CSA Z259.12-16

Net weight : 3.0 oz. / 85 g

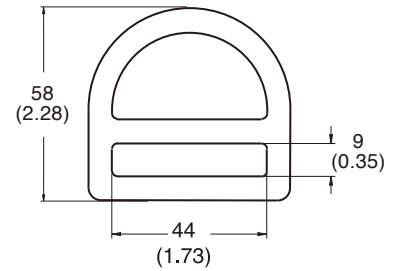

Polished

mm (inch)

N-402-S

D-Ring

Stainless steel, SUS 304

Min. Breaking load : 5000 lbs / 23 kN

Net weight : 3.5 oz. / 98 g

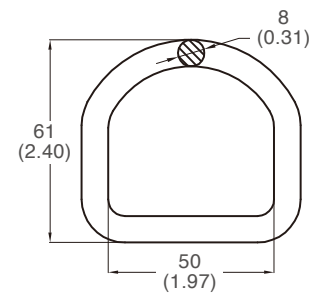

Polished

mm (inch)

N-432-S

D-Ring

Stainless steel, SUS 304

Min. Breaking load : 4000 lbs / 18 kN

Net weight : 2.8 oz. / 80 g

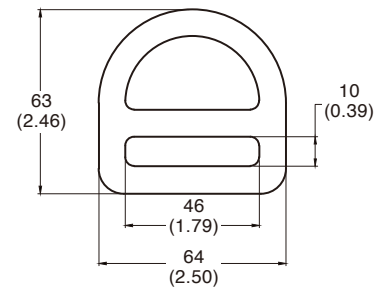

Polished

mm (inch)

N-432A-S

D Ring

Stainless steel, SUS 304

Min. Breaking load : 5000 lbs / 23 kN

Net weight : 2.8 oz. / 80 g

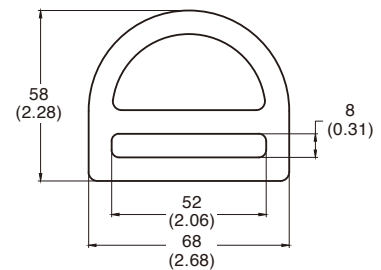

Polished

mm (inch)

New

N-431-S

Bent D-Ring

Stainless steel, SUS 304

Min. Breaking load : 4000 lbs / 18 kN

Net weight : 2.8 oz. / 80 g

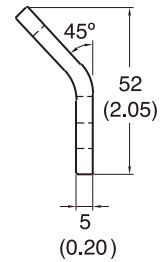
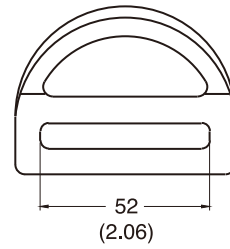

Polished

mm (inch)

N-414-S

D-Ring

Stainless steel, SUS 304

100% proof loaded to 3600 lbs / 16 kN

Min. Breaking load : 5000 lbs / 23 kN

Meets :

- ANSI Z359.12-2019

- CSA Z259.12-16

Net weight : 5.6 oz. / 159 g

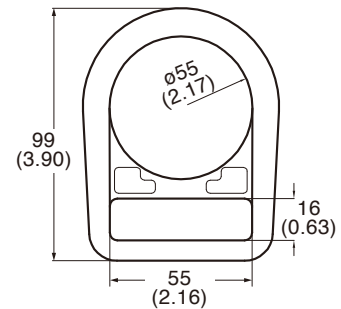

Polished

mm (inch)

N-415-S

D-Ring

Stainless steel, SUS 304

100% proof loaded to 3600 lbs / 16 kN

Min. Breaking load : 5000 lbs / 23 kN

Meets :

- ANSI Z359.12-2019

- CSA Z259.12-16

Net weight : 4.9 oz. / 140 g

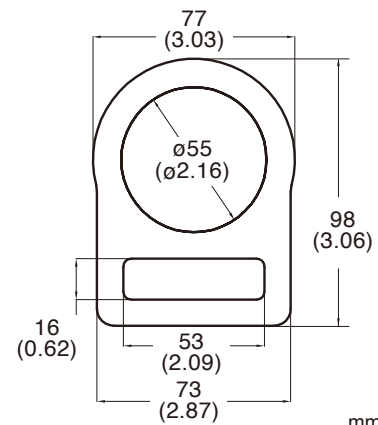

Polished

mm (inch)

N-420-S

Quick Buckle

Stainless steel, SUS 304

Min. Breaking load : 4000 lbs / 18 kN

Meets :

- ANSI Z359.12-2019

- CSA Z259.12-16

Net weight : 1.0 oz. / 28 g

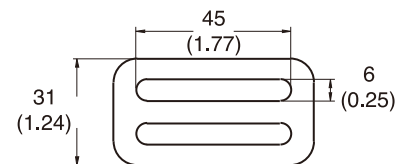

Polished

mm (inch)

**N-422-S
Quick Buckle**

Stainless steel, SUS 304
 Min. Breaking load : 4000 lbs / 18 kN
 Meets :
 ● ANSI Z359.12-2019
 ● CSA Z259.12-16
 Net weight : 1.1 oz. / 31 g

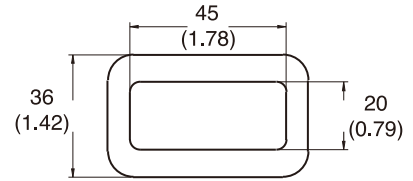

Polished

mm (inch)

**N-421-S
Quick Buckle**

Stainless steel, SUS 304
 Min. Breaking load : 4000 lbs / 18 kN
 Meets :
 ● ANSI Z359.12-2019
 ● CSA Z259.12-16
 Net weight : 1.8 oz. / 50 g

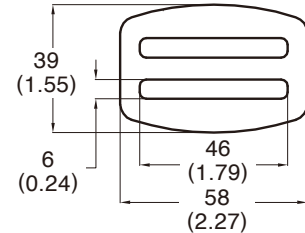

Polished

mm (inch)

**N-423-S
Quick Buckle**

Stainless steel, SUS 304
 Min. Breaking load : 4000 lbs / 18 kN
 Meets :
 ● ANSI Z359.12-2019
 ● CSA Z259.12-16
 Net weight : 2.4 oz. / 69 g

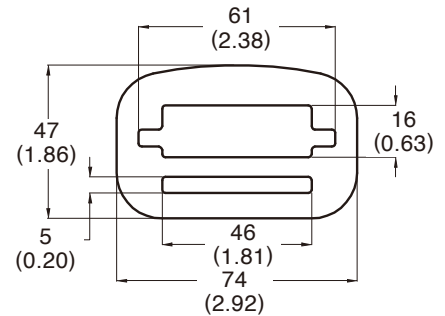

Polished

mm (inch)

**N-448-S
Carabiner**

Stainless steel, SUS 304
 Min. Breaking load : 4000 lbs / 18 kN
 Meets :
 ● ANSI Z359.12-2019
 ● CSA Z259.12-16
 Net weight : 2.4 oz. / 69 g

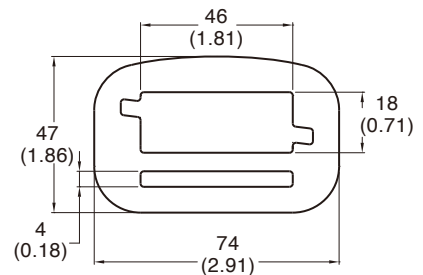

Polished

mm (inch)

New

**N-244-0-S
Carabiner**

Stainless steel, SUS 304
 Min. Breaking load : 5000 lbs / 23 kN
 Meets :
 ● EN 362 : 2004
 Net weight : 6.0 oz. / 169 g

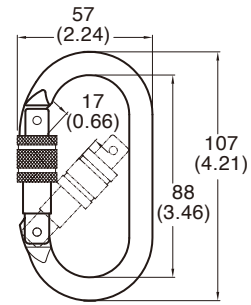

Polished

mm (inch)

**N-252-S
Carabiner**

Stainless steel, SUS 304
 Min. Breaking load : 5000 lbs / 23 kN
 Meets :
 ● EN 362 : 2004
 Net weight : 9.0 oz. / 255 g

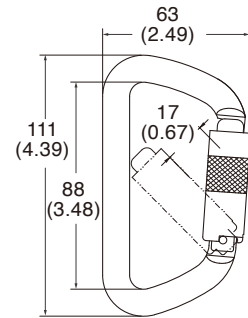

Polished

mm (inch)

**N-256-S
Carabiner**

Stainless steel, SUS 304
 Min. Breaking load : 5000 lbs / 23 kN
 Meets :
 ● EN 362 : 2004
 Net weight : 8.8 oz. / 250 g

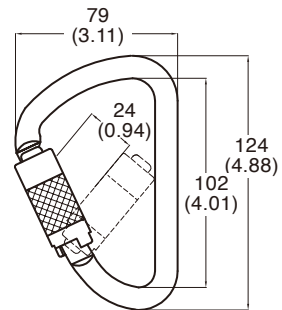

Polished

mm (inch)

**N-268G-S
Carabiner** 3600 LBS gate strength

Stainless steel, SUS 420
 100% proof loaded to 3600 lbs / 16 kN
 Min. Breaking load : 5000 lbs / 23 kN
 Meets:

- EN Z359.12-16
- CSA Z259.12-16

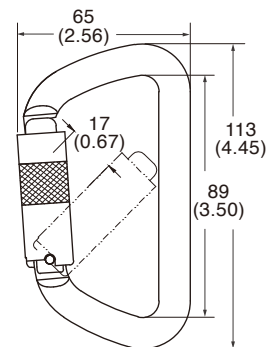

Art. No.	3600 Lbs Gate Strength	Gate Feature		Body
		Twist Locking	Triple Locking	Captive Pin
N-268G-CP-S	✓	✓		✓
N-268G-TRCP-S	✓		✓	✓

Net weight : 8.9 oz. / 254 g
 Zinc Plated

mm (inch)

N-3610-S

Rope Snap Hook
3600 LBS gate strength

Forged Stainless steel, SUS 420

100% proof loaded to 3600 lbs / 16 kN

Min. Breaking load : 5000 lbs / 23 kN

Meets :

- ANSI Z359.12-2019
- CSA Z259.12-16

Net weight : 13.7 oz. / 391 g

Zinc Plated

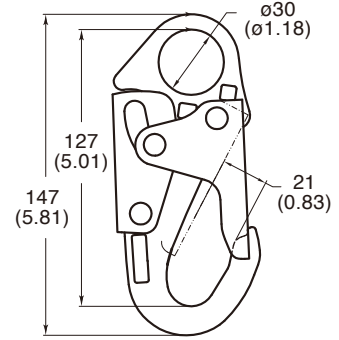

mm (inch)

N-3615-S

Indicator Swivel Snap Hook
3600 LBS gate strength

Forged Stainless steel, SUS 420

100% proof loaded to 3600 lbs / 16 kN

Min. Breaking load : 5000 lbs / 23 kN

Meets :

- ANSI Z359.12-2019
- CSA Z259.12-16

Net weight : 18.0 oz. / 514 g

Zinc Plated



Indicator activation

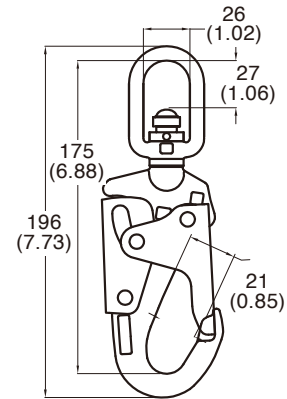

mm (inch)

N-3616-S

Swivel Snap Hook
3600 LBS gate strength

Forged stainless Steel, SUS 420

100% proof loaded to 3600 lbs / 16 kN

Min. Breaking load : 5000 lbs / 23 kN

Meets :

- ANSI Z359.12-2019
- CSA Z259.12-16

Net weight : 17.6 oz. / 504 g

Zinc plated

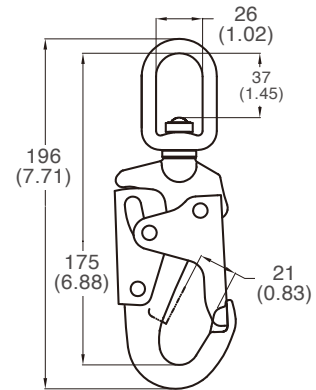

mm (inch)

YOKE



YOKE carabiners are tested by :

100% proof loaded to 3600 lbs / 16 kN
Min. Breaking load : 5000 lbs / 23 kN
Meets ANSI Z359.12-2019 CSA Z259.12-16 EN 362:2004



YOKE has expanded our carabiner offering to include Aluminum and Steel carabiners. YOKE also offers carabiners in four different versions to better meet varying workplace demands :

- Twist lock gate
- Screw lock gate
- Triple lock gate
- With or Without captive pin

YOKE **Aluminum & Steel Carabiners** the model with "G" are ANSI/CSA compliant for 3600 lbs gate strength.

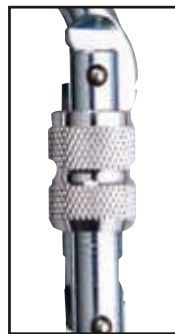
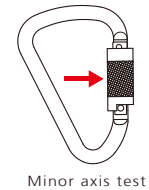
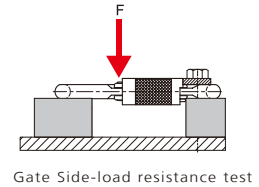
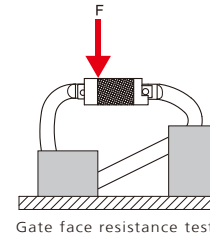

Screw Gate



Twist Locking



Triple Locking (TR)



Captive Pin (CP)

Nose Design



The "SNAG FREE" icon means that the carabiner body / gate has a smooth notch where the nose of the carabiner and gate meet. this smooth area prevents the carabiner from becoming 'snagged' on attachment points such as webbing, d-ring, etc.

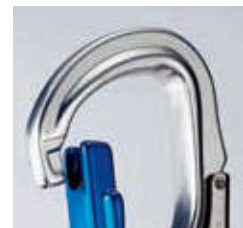

100% proof loaded to 3600 lbs / 16 kN
Min. Breaking load : 5000 lbs / 23 kN
Meets ANSI Z359.12-2019 CSA Z259.12-16 EN 362:2004



N-250GK

Steel Carabiner 3600 LBS gate strength

Alloy steel, heat treated

Art. No.	3600 Lbs Gate Strength	Gate Feature			Body
		Screw gate	Twist Locking	Triple Locking	Captive Pin
N-250GK	✓		✓		
N-250GK-TR	✓			✓	
N-250GK-CP	✓		✓		✓
N-250GK-TRCP	✓			✓	✓

Zinc Plated

Net weight : 7.6 oz. / 216 g

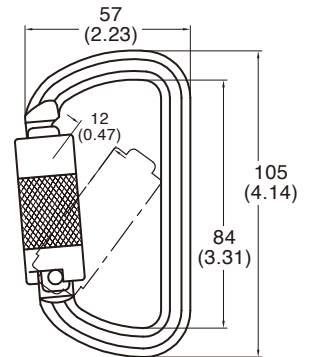

mm (inch)

N-250G

Steel Carabiner 3600 LBS gate strength

Alloy steel, heat treated

Art. No.	3600 Lbs Gate Strength	Gate Feature			Body
		Screw gate	Twist Locking	Triple Locking	Captive Pin
N-250-0		✓			
N-250			✓		
N-250G	✓		✓		
N-250G-TR	✓			✓	
N-250G-CP	✓		✓		✓
N-250G-TRCP	✓			✓	✓

Zinc Plated

Net weight : 7.6 oz. / 215 g

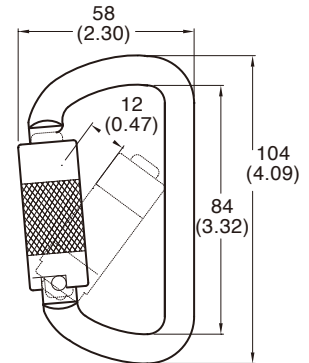

mm (inch)

N-244G

Steel Carabiner 3600 LBS gate strength

Alloy steel, heat treated

Art. No.	3600 Lbs Gate Strength	Gate Feature			Body
		Screw gate	Twist Locking	Triple Locking	Captive Pin
N-244-0		✓			
N-244			✓		
N-244G	✓		✓		
N-244G-TR	✓			✓	
N-244G-CP	✓		✓		✓
N-244G-TRCP	✓			✓	✓

Zinc Plated

Net weight : 7.6 oz. / 215 g



N-244-0

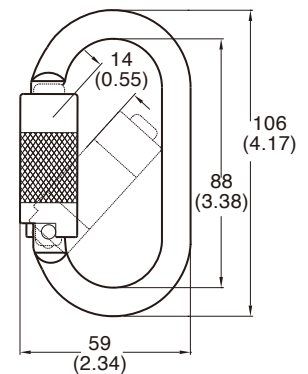

mm (inch)

YOKE carabiners are tested by :

100% proof loaded to 3600 lbs / 16 kN
Min. Breaking load : 5000 lbs / 23 kN
Meets ANSI Z359.12-2019 CSA Z259.12-16 EN 362:2004



N-252GK

Steel Carabiner 3600 LBS gate strength

Alloy steel, heat treated

Art. No.	3600 Lbs Gate Strength	Gate Feature			Body
		Screw gate	Twist Locking	Triple Locking	Captive Pin
N-252GK	✓		✓		
N-252GK-TR	✓			✓	
N-252GK-CP	✓		✓		✓
N-252GK-TRCP	✓			✓	✓

Zinc Plated

Net weight : 8.8 oz. / 252 g.

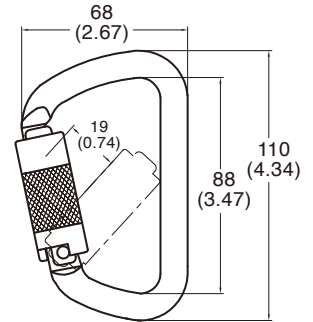

mm (inch)

N-252G

Steel Carabiner 3600 LBS gate strength

Alloy steel, heat treated

Art. No.	3600 Lbs Gate Strength	Gate Feature			Body
		Screw gate	Twist Locking	Triple Locking	Captive Pin
N-252-0		✓			
N-252			✓		
N-252G	✓		✓		
N-252G-TR	✓			✓	
N-252G-CP	✓		✓		✓
N-252G-TRCP	✓			✓	✓

Zinc Plated

Net weight : 8.8 oz. / 250 g.

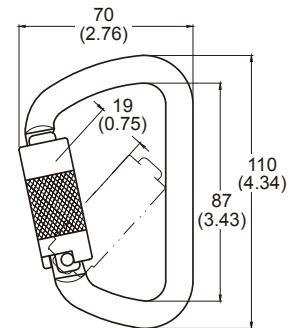

mm (inch)

N-256G

Steel Carabiner 3600 LBS gate strength

Alloy steel, heat treated

Art. No.	3600 Lbs Gate Strength	Gate Feature			Body
		Screw gate	Twist Locking	Triple Locking	Captive Pin
N-256-0		✓			
N-256			✓		
N-256G	✓		✓		
N-256G-TR	✓			✓	
N-256G-CP	✓		✓		✓
N-256G-TRCP	✓			✓	✓

Zinc Plated

Net weight : 9.8 oz. / 279 g.

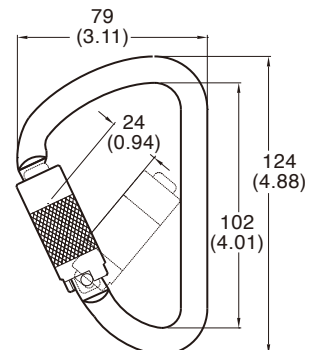

mm (inch)

100% proof loaded to 3600 lbs / 16 kN
Min. Breaking load : 5000 lbs / 23 kN
Meets ANSI Z359.12-2019 CSA Z259.12-16 EN 362:2004



N-245G

Steel Carabiner 3600 LBS gate strength

Alloy steel, heat treated

Art. No.	3600 Lbs Gate Strength	Gate Feature			Body
		Screw gate	Twist Locking	Triple Locking	Captive Pin
N-245-0		✓			
N-245			✓		
N-245G	✓		✓		
N-245G-TR	✓			✓	
N-245G-CP	✓		✓		✓
N-245G-TRCP	✓			✓	✓

Zinc Plated

Net weight : 7.1 oz. / 200 g.

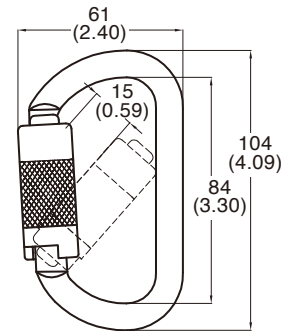

mm (inch)

N-251G

Steel Carabiner 3600 LBS gate strength

Alloy steel, heat treated

Art. No.	3600 Lbs Gate Strength	Gate Feature			Body
		Screw gate	Twist Locking	Triple Locking	Captive Pin
N-251-0		✓			
N-251			✓		
N-251G	✓		✓		
N-251G-TR	✓			✓	
N-251G-CP	✓		✓		✓
N-251G-TRCP	✓			✓	✓

Zinc Plated

Net weight : 8.0 oz. / 226 g.

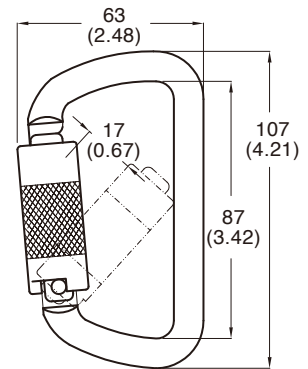

mm (inch)

N-268G

Steel Carabiner 3600 LBS gate strength

Alloy steel, heat treated

Art. No.	3600 Lbs Gate Strength	Gate Feature			Body
		Screw gate	Twist Locking	Triple Locking	Captive Pin
N-268-0		✓			
N-268			✓		
N-268G	✓		✓		
N-268G-TR	✓			✓	
N-268G-CP	✓		✓		✓
N-268G-TRCP	✓			✓	✓

Zinc Plated

Net weight : 9.9 oz. / 280 g.

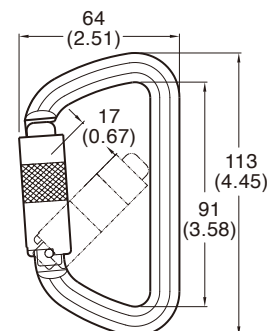

mm (inch)

100% proof loaded to 3600 lbs / 16 kN
Min. Breaking load : 5000 lbs / 23 kN
Meets ANSI Z359.12-2019 CSA Z259.12-16 EN 362:2004

N-267G

Steel Carabiner 3600 LBS gate strength

Alloy steel, heat treated

Art. No.	3600 Lbs Gate Strength	Gate Feature			Body
		Screw gate	Twist Locking	Triple Locking	Captive Pin
N-267-0		✓			
N-267			✓		
N-267G	✓		✓		
N-267G-TR	✓			✓	
N-267G-CP	✓		✓		✓
N-267G-TRCP	✓			✓	✓

Zinc Plated

Net weight : 7.7 oz. / 219 g.

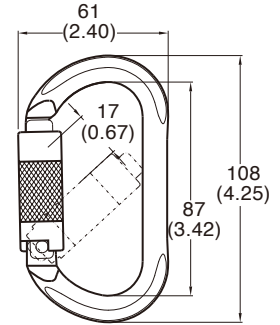

mm (inch)

N-246G

Steel Carabiner 3600 LBS gate strength

Alloy steel, heat treated

Art. No.	3600 Lbs Gate Strength	Gate Feature			Body
		Screw gate	Twist Locking	Triple Locking	Captive Pin
N-246-0		✓			
N-246			✓		
N-246G	✓		✓		
N-246G-TR	✓			✓	
N-246G-CP	✓		✓		✓
N-246G-TRCP	✓			✓	✓

Zinc Plated

Net weight : 10.1 oz. / 288 g.

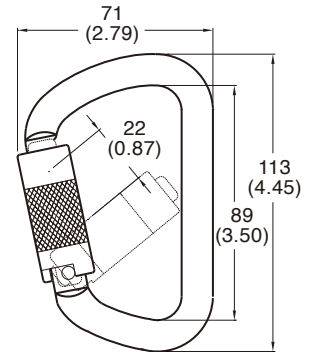

mm (inch)

N-254G

Steel Carabiner 3600 LBS gate strength

Alloy steel, heat treated

Art. No.	3600 Lbs Gate Strength	Gate Feature			Body
		Screw gate	Twist Locking	Triple Locking	Captive Pin
N-254-0		✓			
N-254-CP			✓		✓
N-254-TRCP				✓	✓
N-254G	✓	✓	✓		
N-254G-TR	✓			✓	
N-254G-CP	✓		✓		✓
N-254G-TRCP	✓			✓	✓

Zinc Plated

Net weight : 12.9 oz. / 369 g.

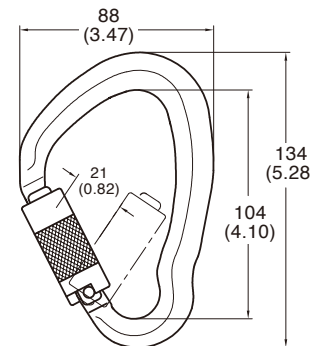

mm (inch)

100% proof loaded to 3600 lbs / 16 kN
Min. Breaking load : 5000 lbs / 23 kN
Meets ANSI Z359.12-2019 CSA Z259.12-16 EN 362:2004



N-248G

Steel Carabiner 3600 LBS gate strength

Alloy steel, heat treated

Art. No.	3600 Lbs Gate Strength	Gate Feature			Body
		Screw gate	Twist Locking	Triple Locking	Captive Pin
N-248-0		✓			
N-248			✓		
N-248G	✓		✓		
N-248G-TR	✓			✓	
N-248G-CP	✓		✓		✓
N-248G-TRCP	✓			✓	✓

Zinc Plated

Net weight : 10.5 oz. / 299 g.

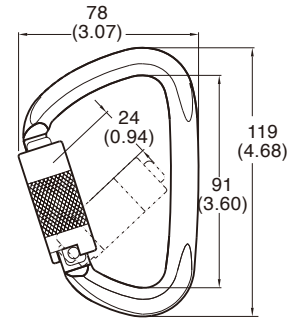

mm (inch)

N-261G

Steel Carabiner 3600 LBS gate strength

Alloy steel, heat treated

Art. No.	3600 Lbs Gate Strength	Gate Feature			Body
		Screw gate	Twist Locking	Triple Locking	Captive Pin
N-261-0		✓			
N-261			✓		
N-261G	✓		✓		
N-261G-TR	✓			✓	

Zinc Plated

Net weight : 10.7 oz. / 305 g.

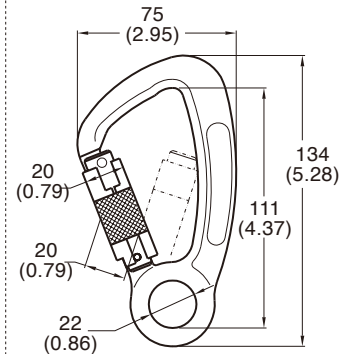

mm (inch)

N-2615G

Indicator Swivel Steel Carabiner

3600 LBS gate strength

Alloy steel, heat treated

Art. No.	3600 Lbs Gate Strength	Gate Feature			Body
		Screw gate	Twist Locking	Triple Locking	Captive Pin
N-2615-0		✓			
N-2615			✓		
N-2615G	✓		✓		
N-2615G-TR	✓			✓	

Zinc Plated

Net weight : 14.9 oz. / 423 g.

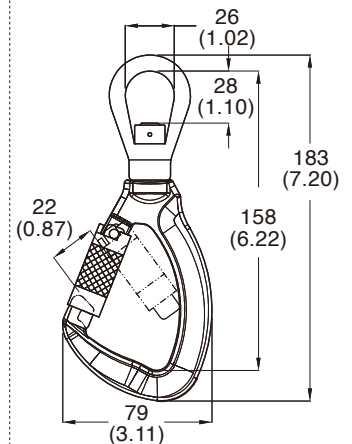

mm (inch)

YOKE carabiners are tested by :

100% proof loaded to 3600 lbs / 16 kN
Min. Breaking load : 5000 lbs / 23 kN
Meets ANSI Z359.12-2019 CSA Z259.12-16 EN 362:2004



N-247G-CP

Steel Carabiner 3600 LBS gate strength

Alloy steel, heat treated

Art. No.	3600 Lbs Gate Strength	Gate Feature			Body
		Screw gate	Twist Locking	Triple Locking	Captive Pin
N-247-0		✓			
N-247			✓		
N-247G-CP	✓		✓		✓
N-247G-TRCP	✓			✓	✓

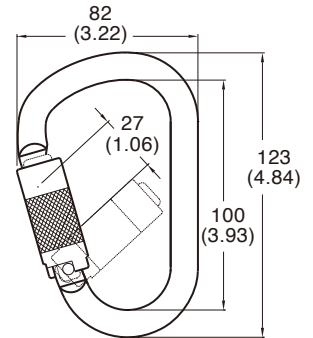

Zinc Plated

Net weight : 11.0 oz. / 313 g.

mm (inch)

N-258G-CP

Steel Carabiner 3600 LBS gate strength

Alloy steel, heat treated

Art. No.	3600 Lbs Gate Strength	Gate Feature			Body
		Screw gate	Twist Locking	Triple Locking	Captive Pin
N-258			✓		
N-258G-CP	✓		✓		✓
N-258G-TRCP	✓			✓	✓

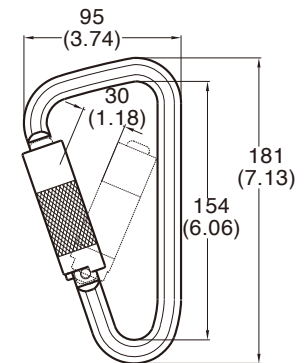

Zinc Plated

Net weight : 22.0 oz. / 625 g.

mm (inch)

N-263G-CP

Steel Carabiner 3600 LBS gate strength

Alloy steel, heat treated

Art. No.	3600 Lbs Gate Strength	Gate Feature			Body
		Screw gate	Twist Locking	Triple Locking	Captive Pin
N-263-0		✓			
N-263			✓		
N-263G-CP	✓		✓		✓
N-263G-TRCP	✓			✓	✓

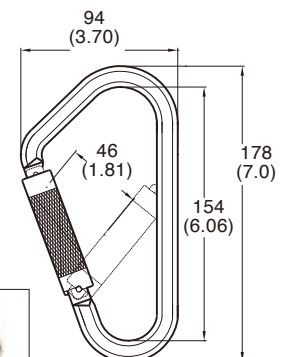

Zinc Plated

Net weight : 15.8 oz. / 447 g.

mm (inch)

100% proof loaded to 3600 lbs / 16 kN
Min. Breaking load : 5000 lbs / 23 kN
Meets ANSI Z359.12-2019 CSA Z259.12-16 EN 362:2004



N-259G-CP

Steel Carabiner 3600 LBS gate strength

Alloy steel, heat treated

Art. No.	3600 Lbs Gate Strength	Gate Feature			Body
		Screw gate	Twist Locking	Triple Locking	Captive Pin
N-259			✓		
N-259G-CP	✓		✓		✓
N-259G-TRCP	✓			✓	✓

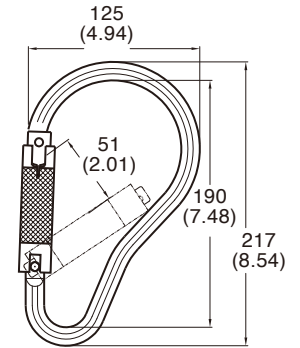

Zinc Plated

Net weight : 27.3 oz. / 774 g.

mm (inch)

N-265G-CP

Steel Carabiner 3600 LBS gate strength

Alloy steel, heat treated

Art. No.	3600 Lbs Gate Strength	Gate Feature			Body
		Screw gate	Twist Locking	Triple Locking	Captive Pin
N-265			✓		
N-265G-CP	✓		✓		✓
N-265G-TRCP	✓			✓	✓

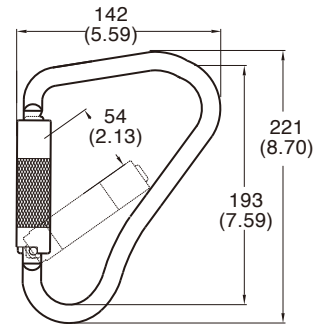

Zinc Plated

Net weight : 28.8 oz. / 817 g.

mm (inch)

100% proof loaded to 3600 lbs / 16 kN
Min. Breaking load : 5000 lbs / 23 kN
Meets ANSI Z359.12-2019 CSA Z259.12-16 EN 362:2004

Steel Carabiner

Art. NO.	N-250G	N-244G	N-245G	N-251G	N-267G	N-252G	N-246G	N-268G	N-248G
Ø mm (inch)	10 (0.39)	10 (0.39)	10 (0.39)	10 (0.39)	10 (0.39)	11 (0.43)	12 (0.47)	12 (0.47)	12 (0.47)
Breaking load minimum (kN)	40 (kN)	25 (kN)	25 (kN)	30 (kN)	30 (kN)	41 (kN)	45 (kN)	50 (kN)	50 (kN)
Gate opening mm (inch)	12 (0.47)	14 (0.55)	15 (0.59)	17 (0.67)	17 (0.67)	19 (0.75)	22 (0.87)	17 (0.67)	24 (0.94)
O.L. mm (inch)	104 (4.09)	106 (4.17)	106 (4.17)	107 (4.21)	108 (4.25)	111 (4.37)	113 (4.45)	113 (4.45)	119 (4.68)

Steel Carabiner

Art. NO.	N-247G	N-256G	N-254G	N-261G	N-263G	N-258G	N-2615G	N-259G	N265G
Ø mm (inch)	12 (0.47)	11 (0.43)	18 (0.71)	--	12 (0.47)	14 (0.55)	--	14 (0.55)	14 (0.55)
Breaking load minimum (kN)	30 (kN)	45 (kN)	50 (kN)	45 (kN)	35 (kN)	50 (kN)	35 (kN)	35 (kN)	45 (kN)
Gate opening mm (inch)	27 (1.06)	24 (0.94)	21 (0.82)	20 (0.79)	46 (1.81)	30 (1.18)	22 (0.87)	51 (2.01)	54 (2.13)
O.L. mm (inch)	123 (4.84)	124 (4.88)	134 (5.28)	134 (5.28)	178 (7.01)	181 (7.13)	183 (7.20)	217 (8.54)	221 (8.70)



YOKE Aluminum carabiners are tested by :

Min. Breaking load : 5000 lbs / 23 kN
Meets EN 362:2004



N-281
Aluminum Carabiner

Aluminum alloy, SAE 7075

Art. No.	Gate Feature			Body
	Screw Gate	Twist Locking	Triple Locking	Captive Pin
N-281-0	✓			
N-281		✓		
N-281-TR			✓	
N-281-CP		✓		✓
N-281-TRCP			✓	✓

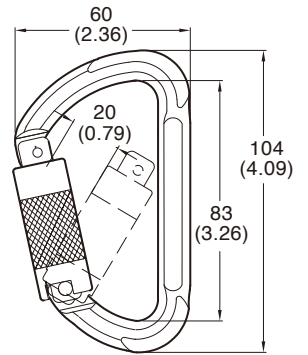

Anodized Net weight : 2.3 oz. / 66 g.

mm (inch)

N-271
Aluminum Carabiner

Aluminum alloy, SAE 7075

Art. No.	Gate Feature			Body
	Screw Gate	Twist Locking	Triple Locking	Captive Pin
N-271-0	✓			
N-271		✓		
N-271-TR			✓	
N-271-CP		✓		✓
N-271-TRCP			✓	✓

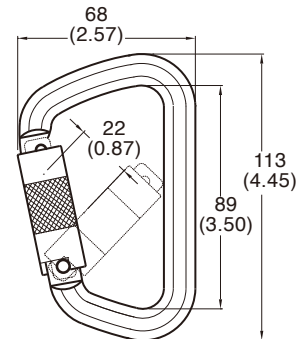

Anodized Net weight : 3.4 oz. / 96 g.

mm (inch)

N-282
Aluminum Carabiner

Aluminum alloy, SAE 7075

Art. No.	Gate Feature			Body
	Screw Gate	Twist Locking	Triple Locking	Captive Pin
N-282-0	✓			
N-282		✓		
N-282-TR			✓	
N-282-CP		✓		✓
N-282-TRCP			✓	✓

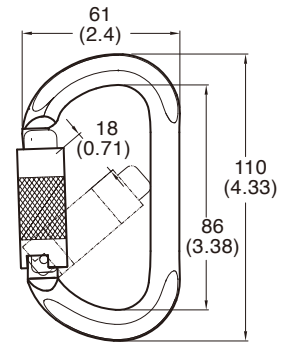

Anodized Net weight : 3.0 oz. / 86 g.

mm (inch)

N-283
Aluminum Carabiner

Aluminum alloy, SAE 7075

Art. No.	Gate Feature			Body
	Screw Gate	Twist Locking	Triple Locking	Captive Pin
N-283-0	✓			
N-283		✓		
N-283-TR			✓	
N-283-CP		✓		✓
N-283-TRCP			✓	✓

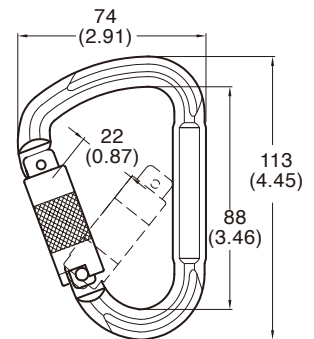

Anodized Net weight : 3.5 oz. / 98 g.

mm (inch)

N-284
Aluminum Carabiner

Aluminum alloy, SAE 7075

Art. No.	Gate Feature			Body
	Screw Gate	Twist Locking	Triple Locking	Captive Pin
N-284-0	✓			
N-284		✓		
N-284-TR			✓	
N-284-CP		✓		✓
N-284-TRCP			✓	✓

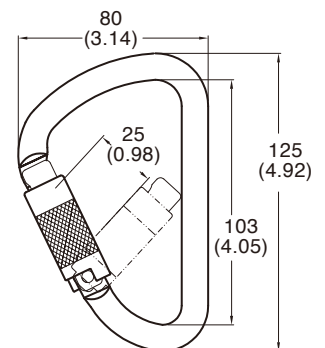

Anodized Net weight : 3.5 oz. / 98 g.

mm (inch)

YOKE Aluminum carabiners are tested by :

Min. Breaking load : 5000 lbs / 23 kN
Meets EN 362:2004



N-274
Aluminum Carabiner

Aluminum alloy, SAE 7075

Art. No.	Gate Feature			Body
	Screw Gate	Twist Locking	Triple Locking	Captive Pin
N-274-0	✓			
N-274		✓		
N-274-TR			✓	
N-274-CP		✓		✓
N-274-TRCP			✓	✓

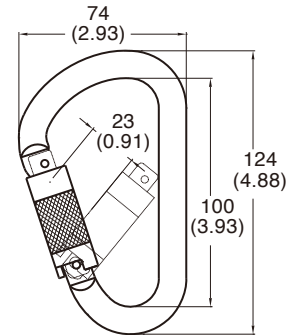

Anodized Net weight : 4.0 oz. / 114 g.

mm (inch)

N-272
Aluminum Carabiner

Aluminum alloy, SAE 7075

Art. No.	Gate Feature			Body
	Screw Gate	Twist Locking	Triple Locking	Captive Pin
N-272-0	✓			
N-272		✓		
N-272-TR			✓	
N-272-CP		✓		✓
N-272-TRCP			✓	✓

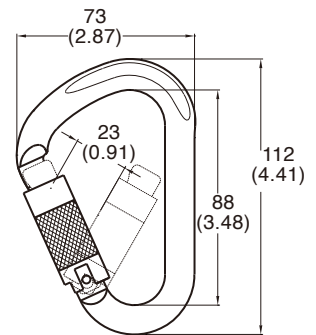

Anodized Net weight : 3.5 oz. / 98 g.

mm (inch)

N-276
Aluminum Carabiner

Aluminum alloy, SAE 7075

Art. No.	Gate Feature			Body
	Screw Gate	Twist Locking	Triple Locking	Captive Pin
N-276-0	✓			
N-276		✓		
N-276-TR			✓	
N-276-CP		✓		✓
N-276-TRCP			✓	✓

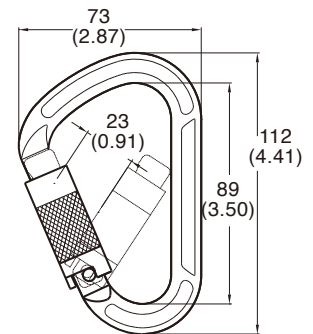

Anodized Net weight : 3.2 oz. / 91 g.

mm (inch)



N-270
Aluminum Carabiner

Aluminum alloy, SAE 7075

Art. No.	Gate Feature			Body
	Screw Gate	Twist Locking	Triple Locking	Captive Pin
N-270-0	✓			
N-270		✓		
N-270-TR			✓	
N-270-CP		✓		✓
N-270-TRCP			✓	✓

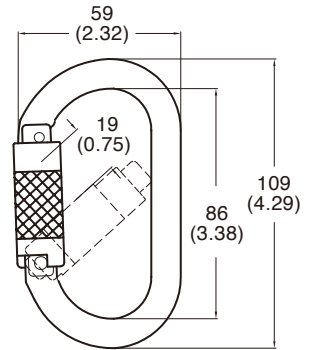

Anodized Net weight : 2.8 oz. / 78 g.

mm (inch)

N-273
Aluminum Carabiner

Aluminum alloy, SAE 7075

Art. No.	Gate Feature			Body
	Screw Gate	Twist Locking	Triple Locking	Captive Pin
N-273-0	✓			
N-273		✓		
N-273-TR			✓	
N-273-CP		✓		✓
N-273-TRCP			✓	✓

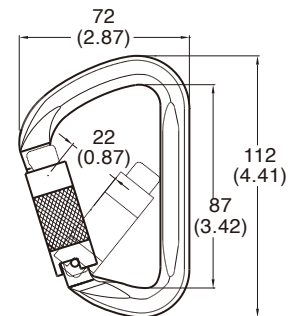

Anodized Net weight : 3.0 oz. / 86 g.

mm (inch)

N-275
Aluminum Carabiner

Aluminum alloy, SAE 7075

Art. No.	Gate Feature			Body
	Screw Gate	Twist Locking	Triple Locking	Captive Pin
N-275-0	✓			
N-275		✓		
N-275-TR			✓	

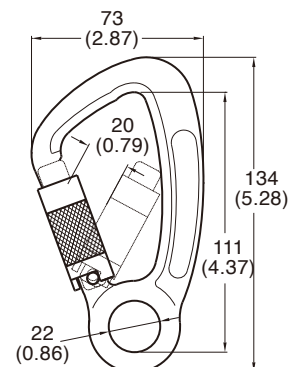

Anodized Net weight : 3.3 oz. / 93 g.

mm (inch)

YOKE Aluminum carabiners are tested by :

Min. Breaking load : 5000 lbs / 23 kN
Meets EN 362:2004



N-287
Aluminum Carabiner

Aluminum alloy, SAE 7075

Art. No.	Gate Feature			Body
	Screw Gate	Twist Locking	Triple Locking	Captive Pin
N-287-0	✓			
N-287		✓		
N-287-TR			✓	
N-287-CP		✓		✓
N-287-TRCP			✓	✓

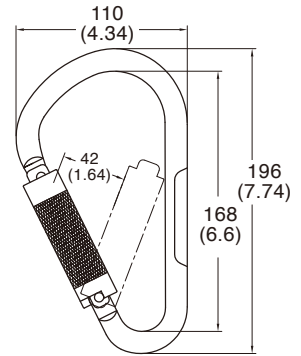

Anodized Net weight : 7.2 oz. / 205 g.

mm (inch)

N-277
Aluminum Carabiner

Aluminum alloy, SAE 7075

Art. No.	Gate Feature		Body
	Twist Locking	Triple Locking	Captive Pin
N-277-CP	✓		✓
N-277-TRCP		✓	✓

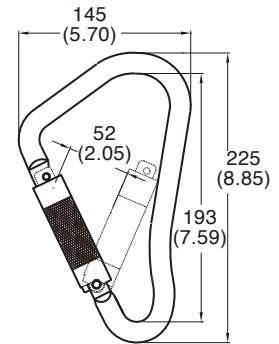

Anodized Net weight : 13.5 oz. / 384 g.

mm (inch)

N-278
Aluminum Carabiner

Aluminum alloy, SAE 7075

Art. No.	Gate Feature		Body
	Twist Locking	Triple Locking	Captive Pin
N-278-CP	✓		✓
N-278-TRCP		✓	✓

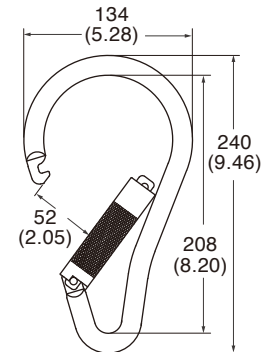

Anodized Net weight : 13.0 oz. / 368 g.

mm (inch)

N-2750
Swivel Aluminum Carabiner

Aluminum alloy, SAE 7075

Art. No.	Gate Feature			Body
	Screw Gate	Twist Locking	Triple Locking	Captive Pin
N-2750-0	✓			
N-2750		✓		
N-2750-TR			✓	

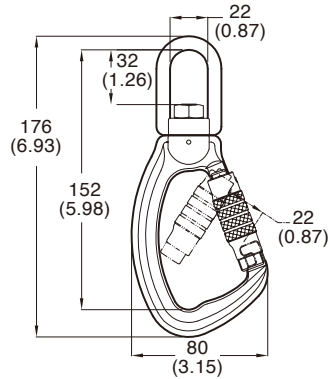

Anodized Net weight : 7.5 oz. / 214 g.

mm (inch)

N-2852
Aluminum Carabiner

Aluminum alloy, SAE 7075

Art. No.	Gate Feature			Body
	Screw Gate	Twist Locking	Triple Locking	Captive Pin
N-2852-0	✓			
N-2852		✓		
N-2852-TR			✓	
N-2852-CP		✓		✓
N-2852-TRCP			✓	✓

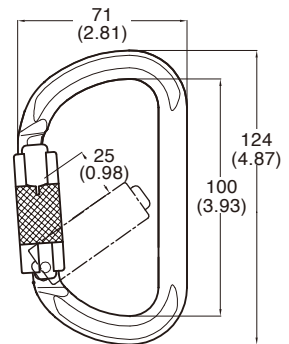

Anodized Net weight : 3.7 oz. / 108 g.

mm (inch)

N-2854
Aluminum Carabiner

Aluminum alloy, SAE 7075

Art. No.	Gate Feature			Body
	Screw Gate	Twist Locking	Triple Locking	Captive Pin
N-2854-0	✓			
N-2854		✓		
N-2854-TR			✓	
N-2854-CP		✓		✓
N-2854-TRCP			✓	✓

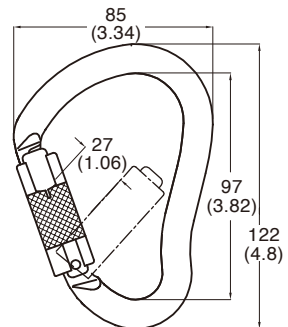

Anodized Net weight : 3.6 oz. / 103 g.

mm (inch)

YOKE Aluminum carabiners are tested by :

Min. Breaking load : 5000 lbs / 23 kN
Meets EN 362:2004



N-2855
Aluminum Carabiner

Aluminum alloy, SAE 7075

Art. No.	Gate Feature			Body
	Screw Gate	Twist Locking	Triple Locking	Captive Pin
N-2855		✓		
N-2855-TR			✓	

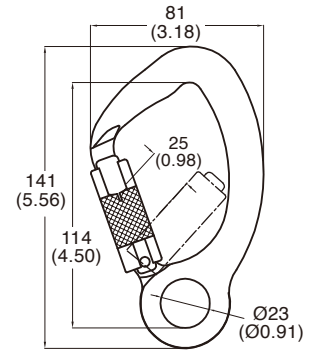

Anodized Net weight : 4.6 oz. / 132 g.

mm (inch)

N-2857
Aluminum Indicator Swivel Carabiner

Aluminum alloy, SAE 7075

Art. No.	Gate Feature			Body
	Screw Gate	Twist Locking	Triple Locking	Captive Pin
N-2857		✓		
N-2857-TR			✓	



Indicator activation

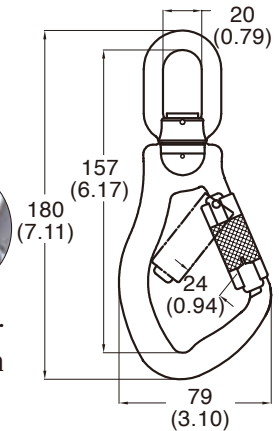

Anodized Net weight : 6.2 oz. / 177 g.

mm (inch)

N-2857 / 0
Aluminum Swivel Carabiner

Aluminum alloy, SAE 7075

Art. No.	Gate Feature			Body
	Screw Gate	Twist Locking	Triple Locking	Captive Pin
N-2857 / 0-0	✓			
N-2857 / 0		✓		
N-2587 / 0-TR			✓	

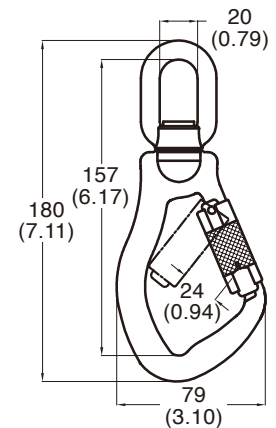

Anodized Net weight : 6.1 oz. / 172 g.

mm (inch)



N-2859
Aluminum Carabiner
 Aluminum alloy, SAE 7075



Art. No.	Gate Feature			Body
	Screw Gate	Twist Locking	Triple Locking	Captive Pin
N-2859-0	✓			
N-2859		✓		
N-2859-TR			✓	
N-2859-CP		✓		✓
N-2859-TRCP			✓	✓

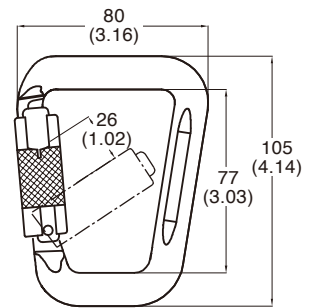

Anodized Net weight : 4.1 oz. / 118 g.

mm (inch)

YOKE Aluminum carabiners are tested by :

Min. Breaking load : 5000 lbs / 23 kN
Meets EN 362:2004



Aluminum Carabiner



Art. NO.	N-281	N-2859	N-270	N-282	N-272	N-273	N-276	N-271	N-283	N-2854
Ø mm (inch)	10 (0.39)	--	11 (0.43)	11 (0.43)	12 (0.47)	--	--	12 (0.47)	12 (0.47)	--
Breaking load minimum (kN)	23 (kN)	23 (kN)	23 (kN)	23 (kN)	23 (kN)	30 (kN)	24 (kN)	25 (kN)	23 (kN)	25 (kN)
Gate opening mm (inch)	20 (0.79)	26 (1.02)	19 (0.75)	18 (0.71)	23 (0.91)	22 (0.87)	23 (0.91)	22 (0.87)	22 (0.87)	27 (1.06)
O.L. mm (inch)	104 (4.09)	105 (4.13)	109 (4.29)	110 (4.33)	112 (4.41)	112 (4.41)	112 (4.41)	113 (4.45)	113 (4.45)	122 (4.80)

Aluminum Carabiner



Art. NO.	N-274	N-2852	N-284	N-275	N-2855	N-2750	N-2857	N-2857 / 0	N-287	N-277	N-278
Ø mm (inch)	12 (0.47)	--	11 (0.43)	--	--	--	--	--	15 (0.59)	16 (0.63)	16 (0.63)
Breaking load minimum (kN)	25 (kN)	23 (kN)	23 (kN)	28 (kN)	30 (kN)	23 (kN)	30 (kN)	30 (kN)	23 (kN)	35 (kN)	23 (kN)
Gate opening mm (inch)	23 (0.91)	25 (0.98)	25 (0.98)	20 (0.79)	25 (0.98)	22 (0.87)	24 (0.94)	24 (0.94)	42 (1.64)	52 (2.05)	52 (2.05)
O.L. mm (inch)	124 (4.88)	124 (4.88)	125 (4.92)	134 (5.28)	141 (5.55)	176 (6.93)	180 (7.09)	180 (7.09)	185 (7.74)	225 (8.85)	239 (9.41)



YOKE carabiners are tested by :

100% proof loaded to 3600 lbs / 16 kN
Min. Breaking load : 5000 lbs / 23 kN
Meets ANSI Z359.12-2019 CSA Z259.12-16 EN 362:2004



N-2852G

Aluminum Carabiner 3600 LBS gate strength

Aluminum alloy, SAE 7075

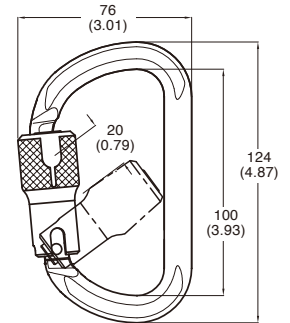

mm (inch)

Art. No.	Gate Feature			Body
	3600Lbs Gate Strength	Twist Locking	Triple Locking	Captive Pin
N-2852G	✓	✓		
N-2852G-TR	✓		✓	
N-2852G-CP	✓	✓		✓
N-2852G-TRCP	✓		✓	✓

Anodized Net weight : 4.6 oz. / 131 g

N-2853G

Aluminum Carabiner 3600 LBS gate strength

Aluminum alloy, SAE 7075

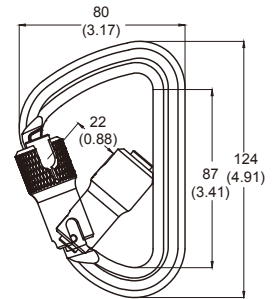

mm (inch)

Art. No.	Gate Feature			Body
	3600Lbs Gate Strength	Twist Locking	Triple Locking	Captive Pin
N-2853G	✓	✓		
N-2853G-TR	✓		✓	
N-2853G-CP	✓	✓		✓
N-2853G-TRCP	✓		✓	✓

Anodized Net weight : 5.3 oz. / 149.1 g

N-2854G

Aluminum Carabiner 3600 LBS gate strength

Aluminum alloy, SAE 7075

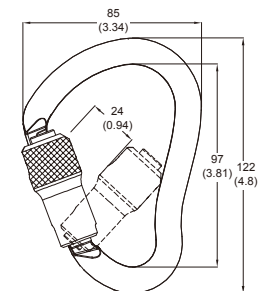

mm (inch)

Art. No.	Gate Feature			Body
	3600Lbs Gate Strength	Twist Locking	Triple Locking	Captive Pin
N-2854G	✓	✓		
N-2854G-TR	✓		✓	
N-2854G-CP	✓	✓		✓
N-2854G-TRCP	✓		✓	✓

Anodized Net weight : 4.37 oz. / 124 g

100% proof loaded to 3600 lbs / 16 kN
Min. Breaking load : 5000 lbs / 23 kN
Meets ANSI Z359.12-2019 CSA Z259.12-16 EN 362:2004



N-2855G

Aluminum Carabiner 3600 LBS gate strength

Aluminum alloy, SAE 7075

Art. No.	Gate Feature		
	3600Lbs Gate Strength	Twist Locking	Triple Locking
N-2855G	✓	✓	
N-2855G-TR	✓		✓

Anodized Net weight : 5.3 oz. / 149.1 g

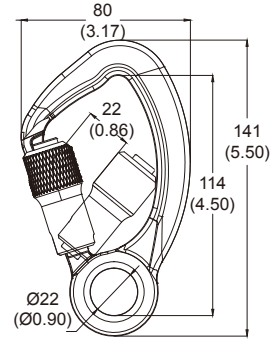

mm (inch)

N-2857G

Aluminum Indicator Swivel Carabiner

3600 LBS gate strength Aluminum alloy, SAE 7075

Art. No.	Gate Feature		
	3600Lbs Gate Strength	Twist Locking	Triple Locking
N-2857G	✓	✓	
N-2857G-TR	✓		✓

Anodized Net weight : 7.2 oz. / 205 g

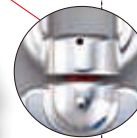

Indicator activation

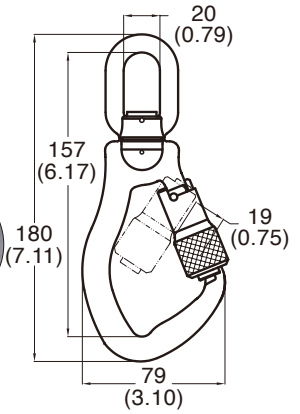

mm (inch)

N-2857 / 0G

Aluminum Swivel Carabiner

3600 LBS gate strength Aluminum alloy, SAE 7075

Art. No.	Gate Feature		
	3600Lbs Gate Strength	Twist Locking	Triple Locking
N-2857 / 0G	✓	✓	
N-2857 / 0G-TR	✓		✓

Anodized Net weight : 7.0 oz. / 200 g

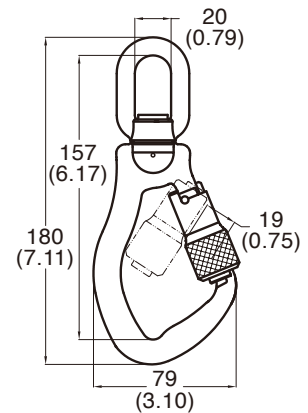

mm (inch)

YOKE carabiners are tested by :

100% proof loaded to 3600 lbs / 16 kN
Min. Breaking load : 5000 lbs / 23 kN
Meets ANSI Z359.12-2019 CSA Z259.12-16 EN 362:2004



N-2859G

Aluminum Carabiner 3600 LBS gate strength

Aluminum alloy, SAE 7075

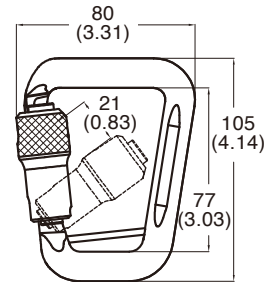

Art. No.	Gate Feature			Body
	3600Lbs Gate Strength	Twist Locking	Triple Locking	Captive Pin
N-2859G	✓	✓		
N-2859G-TR	✓		✓	
N-2859G-CP	✓	✓		✓
N-2859G-TRCP	✓		✓	✓

Anodized Net weigh : 5.0 oz. / 142 g

mm (inch)

N-2868G

Aluminum Carabiner 3600 LBS gate strength

Aluminum alloy, SAE 7075

Meets :

- CSA 259.12-11

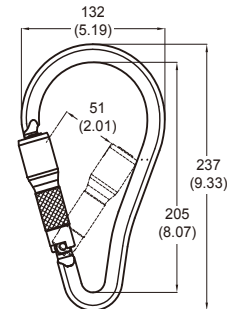

Art. No.	Gate Feature			Body
	3600Lbs Gate Strength	Twist Locking	Triple Locking	Captive Pin
N-2868G-CP	✓	✓		✓
N-2868G-TRCP	✓		✓	✓

Anodized Net weight : 15.9 oz. / 450 g

mm (inch)

SNAG FREE Aluminum Carabiner



Art.NO.	N-2859G	N-2854G	N-2852G	N-2853G	N-2855G	N-2857G	N-2868G
Breaking load minimum(kN)	23 kN	25 kN	23 kN	40 kN	30 kN	30 kN	25 kN
Gate opening mm(inch)	21 (0.83)	24 (0.94)	20 (0.79)	22 (0.87)	22 (0.87)	19 (0.75)	51 (2.01)
O.L mm(inch)	105 (4.13)	122 (4.80)	124 (4.88)	124 (4.88)	141 (5.55)	180 (7.09)	237 (9.33)



N-610
Panic Rope Grab
(Open type)

Stainless steel

For Rope : 16 mm (5 / 8 ")

Min. Breaking load : 3600 lbs / 16 kN

Meets :

- ANSI Z359.1

- EN 353-2

Net weight : 20.2 oz. / 572 g

Polished



Open for attachment

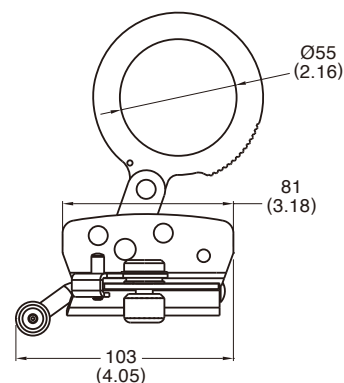

mm (inch)

N-610LY
Rope grab with integral lanyard

Stainless steel

For Rope : 16 mm (5 / 8 ")

Max elongation : 61 in (156 cm)

Max arresting force : 1300 lbs (6 kN)

Max freefall : 3.28 ft (1 m)

Worker mass range : 100-350 lbs (45-160 kgs)

Min. Breaking load : 3600 lbs / 16 kN

Meets :

- CSA Z259.2.5-17

- ANSI Z359.15-14

Net weight : 42.28 oz. / 1208g

Polished



mm (inch)

N-630
Panic Rope Grab
(Open type)

Steel

For Rope : 16 mm (5 / 8 ")

Min. Breaking load : 3600 lbs / 16 kN

Meets :

- ANSI Z359.1

- EN 353-2

Net weigh : 20.2 oz. / 572 g

Zinc Plated



Open for attachment

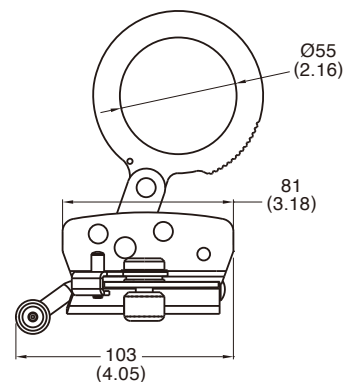

mm (inch)

N-630LY
Rope grab with integral lanyard

Steel

For Rope : 16 mm (5 / 8 ")

Max elongation : 61 in (156 cm)

Max arresting force : 1300 lbs (6 kN)

Max freefall : 3.28 ft (1 m)

Worker mass range : 100-350 lbs (45-160 kgs)

Min. Breaking load : 3600 lbs / 16 kN

Meets :

- CSA Z259.2.5-17

- ANSI Z359.15-14

Net weight : 42.67 oz. / 1208 g

Zinc Plated



mm (inch)

**N-616
Panic Rope Grab
(Open type)**

Stainless steel
 For Rope : 12.7 - 14 mm (1 / 2 " - 9 / 16 ")
 Min. Breaking load : 3600 lbs / 16 kN
 Meets :
 ● ANSI Z359.1
 ● EN 353-2
 Net weight : 20.2 oz. / 572 g



Open for attachment

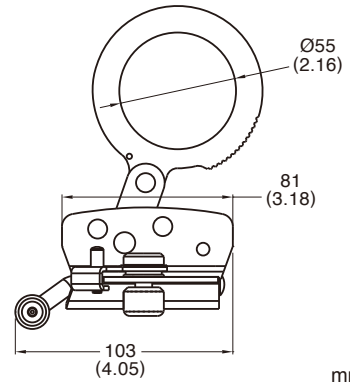

mm (inch)

**N-636
Panic Rope Grab
(Open type)**

Steel
 For Rope : 12.7 - 14 mm (1 / 2 " - 9 / 16 ")
 Min. Breaking load : 3600 lbs / 16 kN
 Meets :
 ● ANSI Z359.1
 ● EN 353-2
 Net weight : 20.8 oz. / 589 g



Open for attachment

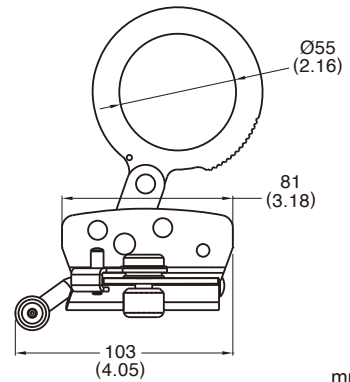

mm (inch)

**N-617
Rope Grab
(Open type)**

Stainless steel
 For Rope : 14 - 16 mm (9 / 16 " - 5 / 8 ")
 Min. Breaking load : 3600 lbs / 16 kN
 Meets :
 ● ANSI Z359.1
 ● EN 353-2
 Net weight : 15.1 oz. / 428 g



Open for attachment

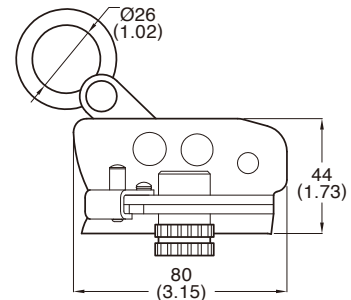

mm (inch)

**N-637
Rope Grab
(Open type)**

Steel
 For Rope : 14 - 16 mm (9 / 16 " - 5 / 8 ")
 Min. Breaking load : 3600 lbs / 16 kN
 Meets :
 ● ANSI Z359.1
 ● EN 353-2
 Net weight : 15.1 oz. / 428 g



Open for attachment

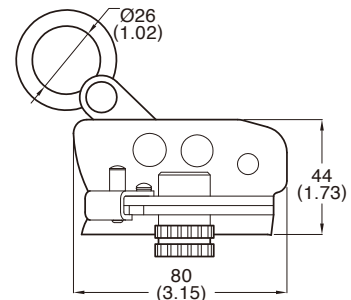

mm (inch)

**N-618
Rope Grab
(Open type)**

Stainless steel

For Rope : 12.7 - 14 mm (1 / 2 " - 9 / 16 ")

Min. Breaking load : 3600 lbs / 16 kN

Meets :

- ANSI Z359.1
- EN 353-2

Net weight : 20.3 oz. / 580 g

Polished



Open for attachment

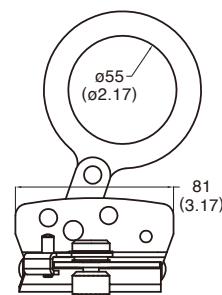

mm (inch)

**N-638
Rope Grab
(Open type)**

Steel

For Rope : 12.7 - 14 mm (1 / 2 " - 9 / 16 ")

Min. Breaking load : 3600 lbs / 16 kN

Meets :

- ANSI Z359.1
- EN 353-2

Net weight : 20.5 oz. / 586 g

Zinc Plated

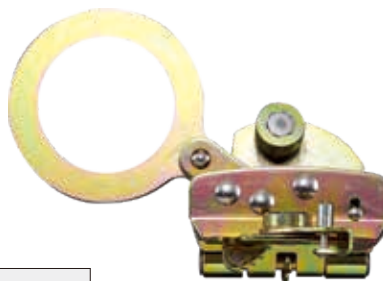

Open for attachment

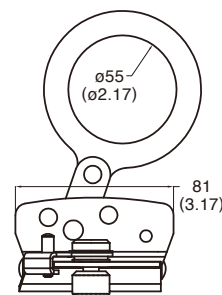

mm (inch)

**N-619T
Rope Grab With Parking Feature
(Open type)**

Stainless Steel

For Rope : 12.7 - 14 mm (1 / 2 " - 9 / 16 ")

Min. Breaking load : 3600 lbs / 16 kN

Meets :

- ANSI Z359.1
- EN 353-2

Net weight : 17.5 oz. / 499 g

Polished



Open for attachment

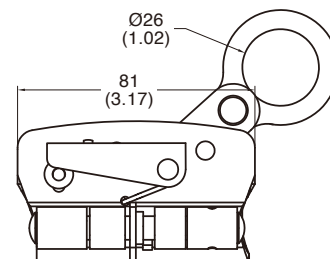

mm (inch)

**N-619
Rope Grab
(Open type)**

Stainless Steel

For Rope : 12.7 - 14 mm (1 / 2 " - 9 / 16 ")

Min. Breaking load : 3600 lbs / 16 kN

Meets :

- ANSI Z359.1
- EN 353-2

Net weight : 14.9 oz. / 428 g

Polished

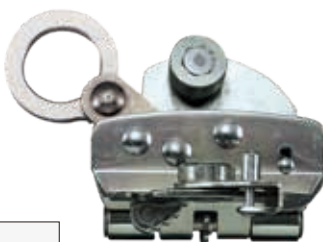

Open for attachment

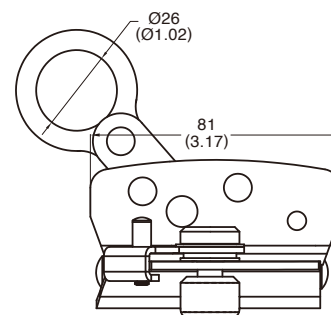

mm (inch)

**N-639
Rope Grab
(Open type)**

Steel

For Rope : 12.7 - 14 mm (1 / 2 " - 9 / 16 ")

Min. Breaking load : 3600 lbs / 16 kN

Meets :

- ANSI Z359.1
- EN 353-2

Net weight : 15.1 oz. / 428 g

Zinc Plated

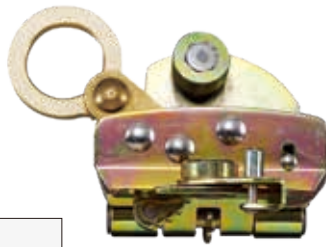

Open for attachment

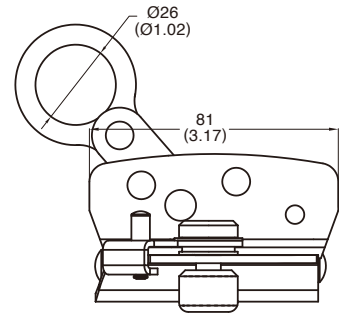

mm (inch)

**N-606AP
Panic Rope Grab-Positioning**

Stainless steel

For Rope : 16 mm (5/8")

Min. Breaking load : 3600 lbs / 16 kN

Meets:

- ANSI Z359.1
- EN 353-2

Net weight : 25.9 oz. / 733 g

Polished



Open for attachment

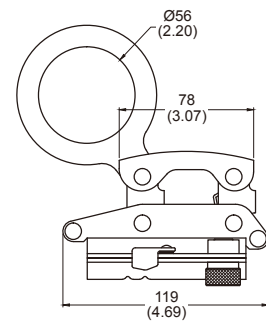

mm (inch)

**N-602-12
Rope Grab with Eye**

Steel

For Rope : 12 mm (1 / 2 ")

Min. Breaking load : 3600 lbs / 16 kN

Meets :

- ANSI Z359.1
- EN 358

Net weight : 14.4 oz. / 441 g

Zinc Plated

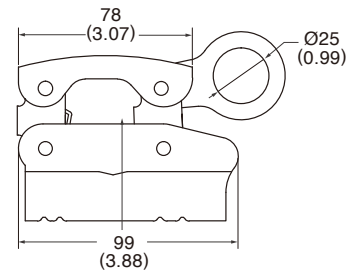

mm (inch)

**N-602
Rope Grab with Eye**

Steel

For Rope : 16 mm (5 / 8 ")

Min. Breaking load : 3600 lbs / 16 kN

Meets :

- ANSI Z359.1
- EN 353-2

Net weight : 16.2 oz. / 458 g

Zinc Plated

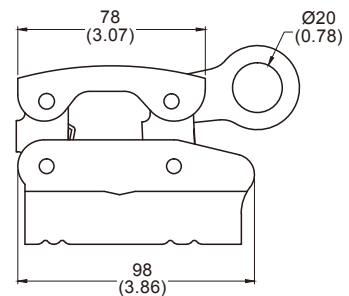

mm (inch)

**N-668
Rope Grab**

Aluminum alloy
Rope size : 11-13 mm
Net weight : 5.6 oz. / 159g

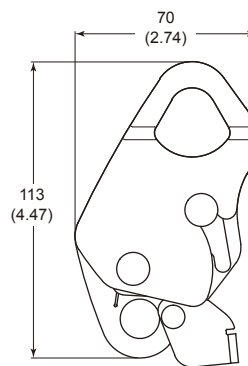

mm (inch)

Anodized

**N-620/N-622
Cable Grab With Eye**

Stainless steel
Min. Breaking load : 3600 lbs / 16 kN
Meets :
● EN 353-2

Art No.	Wire Rope	Net Weight
N-620	8mm(5/16")	16.4 oz./465g
N-622	10mm(3/8")	16.9oz./478g

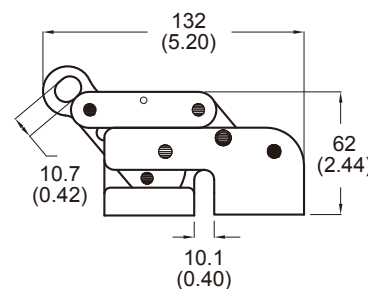

mm (inch)

Polished

**N-621/N-623
Cable Grab With Eye**

Stainless steel
Min. Breaking load : 3600 lbs / 16 kN
Meets :
● ANSI Z359.1
● EN 353-2

Art No.	Wire Rope	Net Weight
N-621	8mm(5/16")	16.8 oz./477g
N-623	10mm(3/8")	17.3oz./490g



Anti-upside down

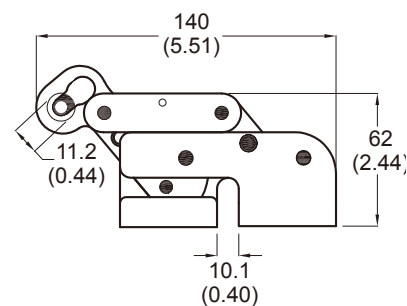

mm (inch)

Polished

**N-604
Rope Grab with Hook**

Steel
For Rope : 16 mm (5 / 8 ")
Min. Breaking load : 3600 lbs / 16 kN
Meets :
● ANSI Z359.1
● EN 353-2
Net weight : 19.3 oz. / 547 g

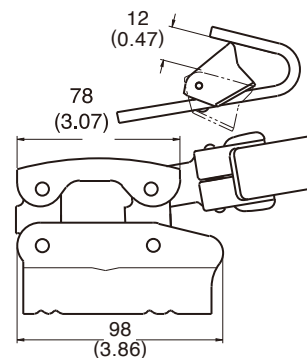

mm (inch)

Zinc Plated

N-650
Rope Grab With Fixed Cam

Aluminum alloy
 Rope size : Ø 9 mm — Ø 13 mm
 Net weight : 5.8 oz. / 166 g

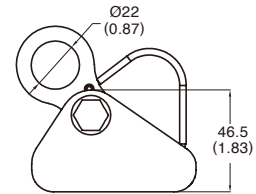

Anodized

mm (inch)

N-650B
Rope Grab With Removable Cam

Aluminum alloy
 Rope size : Ø 9 mm — Ø 13 mm
 Net weight : 6.2 oz. / 177 g

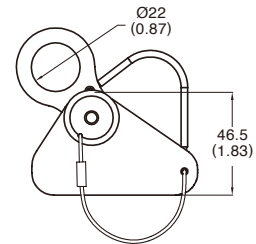

Anodized

mm (inch)

N-651
Rope Adjustor Grab With Fixed Cam

Aluminum alloy
 Rope size : Ø 9 mm — Ø 13 mm
 Net weight : 6.1 oz. / 173 g
Not for fall arrest

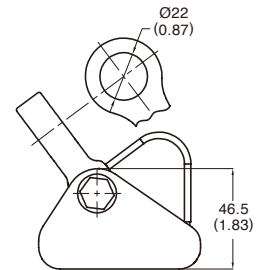

Anodized

mm (inch)

N-651B
Rope Adjustor Grab With Removable Cam

Aluminum alloy
 Rope size : Ø 9 mm — Ø 13 mm
 Net weight : 6.4 oz. / 182 g
Not for fall arrest

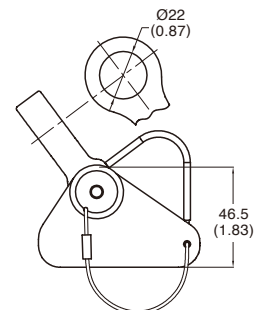

Anodized

mm (inch)

**N-670
Positioning Grab**

Stainless steel / Aluminum alloy
 Rope size : Ø 14 mm — Ø 16 mm
 Net weight : 8.3 oz. / 238 g

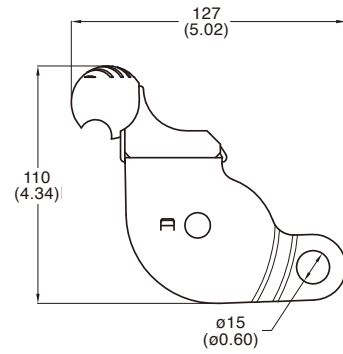

mm (inch)

Polished

**N-660
Rope Grab**

Aluminum alloy
 Rope size : Ø 12 mm
 Net weight : 7.4 oz. / 210 g

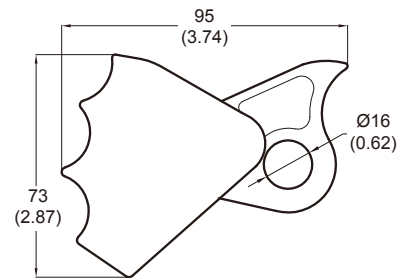

mm (inch)

Anodized

**N-608
Rope Tensioner**

Steel, heat treated
 Rope Size : 16 mm (5 / 8 ")
 Net weight : 58.6 oz. / 1.66 kg

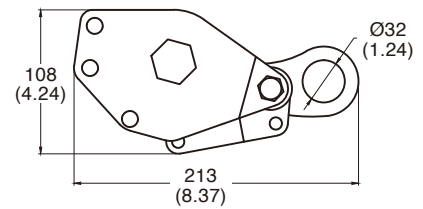
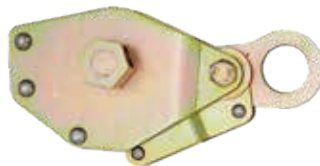

mm (inch)

Zinc Plated

New



N-351
Swivels - Eye to Eye
(non-indicator)

Forged steel, heat treated
 100% proof loaded to 3600 lbs / 16 kN
 Min. Breaking load : 5000 lbs / 23 kN
 Net weight : 6.2 oz. / 176 g

N-3035M
Swivel Eye

Forged steel, heat treated
 Net weight : 2.5 oz. / 72 g

Zinc Plated



N-3035M

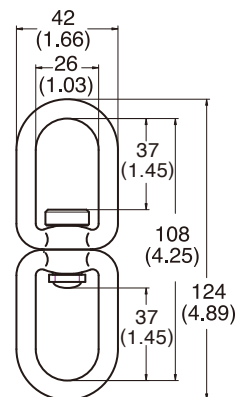

mm (inch)

N-352
Swivels - Jaw to Jaw
(non-indicator)

Forged steel, heat treated
 100% proof loaded to 3600 lbs / 16 kN
 Min. Breaking load : 5000 lbs / 23 kN
 Net weight : 6.3 oz. / 180 g

Zinc Plated

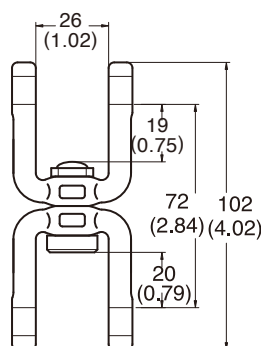

mm (inch)

N-353
Swivels - Jaw to Eye
(non-indicator)

Forged steel, heat treated
 100% proof loaded to 3600 lbs / 16 kN
 Min. Breaking load : 5000 lbs / 23 kN
 Net weight : 6.2 oz. / 175 g

Zinc Plated

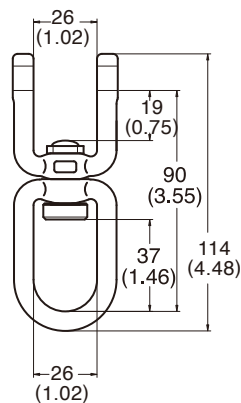

mm (inch)

N-354
Swivels - Eye to Eye
(non-indicator)

Forged steel, heat treated
 100% proof loaded to 3600 lbs / 16 kN
 Min. Breaking load : 5000 lbs / 23 kN
 Net weight : 7.1 oz. / 200 g

Zinc Plated

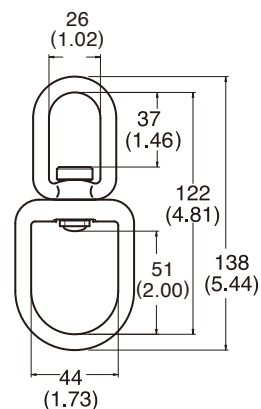

mm (inch)

N-355
Indicator Swivels - Eye to Eye

Forged steel, heat treated
100% proof loaded to 3600 lbs / 16 kN
Min. Breaking load : 5000 lbs / 23 kN
Net weight : 7.4 oz. / 211 g

Zinc Plated



Indicator activation

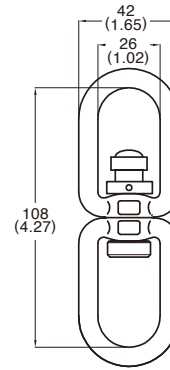

mm (inch)

N-356
Indicator Swivels - Jaw to Jaw

Forged steel, heat treated
100% proof loaded to 3600 lbs / 16 kN
Min. Breaking load : 5000 lbs / 23 kN
Net weight : 6.7 oz. / 190 g

Zinc Plated



Indicator activation

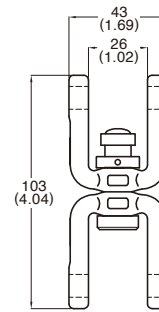

mm (inch)

N-357
Indicator Swivels - Jaw to Eye

Forged steel, heat treated
100% proof loaded to 3600 lbs / 16 kN
Min. Breaking load : 5000 lbs / 23 kN
Net weight : 6.5 oz. / 185 g

Zinc Plated



Indicator activation

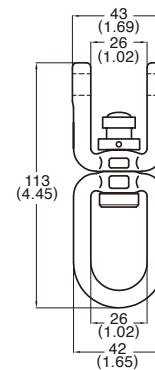

mm (inch)

N-358
Indicator Swivels - Eye to Eye

Forged steel, heat treated
100% proof loaded to 3600 lbs / 16 kN
Min. Breaking load : 5000 lbs / 23 kN
Net weight : 7.4 oz. / 210 g

Zinc Plated



Indicator activation

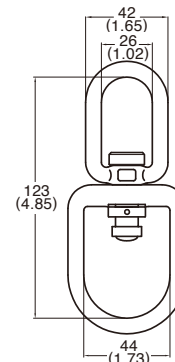

mm (inch)

N-903
Anchorage Connector (1 / 2")

Forged steel, heat treated
 100% proof loaded to 3600 lbs / 16 kN
 Min. Breaking load : 5000 lbs / 23 kN
 for 1 / 2 : (M13) bolt.
 Net weight : 21.2 oz. / 600 g

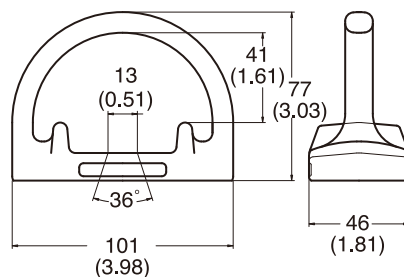

mm (inch)

Zinc Plated

"Warning: Bolts for anchorage connector installation to be minimum grade 8 quality with lock washer."

N-904
Anchorage Connector (5 / 8")

Forged steel, heat treated
 100% proof loaded to 3600 lbs / 16 kN
 Min. Breaking load : 5000 lbs / 23 kN
 for 5 / 8 : (M16) bolt.
 Net weight : 21.3 oz. / 582 g

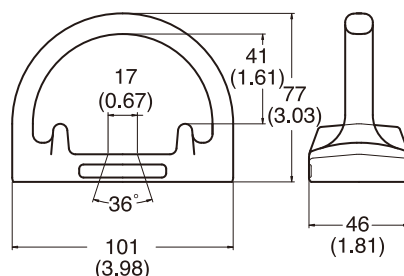

mm (inch)

Zinc Plated

"Warning: Bolts for anchorage connector installation to be minimum grade 8 quality with lock washer."

N-905
Anchorage Connector (3 / 4")

Forged steel, heat treated
 100% proof loaded to 3600 lbs / 16 kN
 Min. Breaking load : 5000 lbs / 23 kN
 for 3 / 4 : (M19) bolt.
 Net weight : 19.6 oz. / 563 g

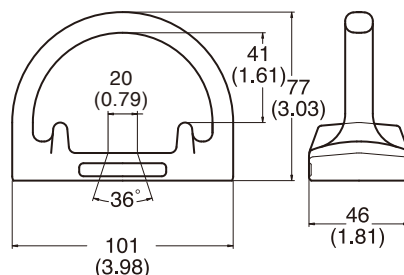

mm (inch)

Zinc Plated

"Warning: Bolts for anchorage connector installation to be minimum grade 8 quality with lock washer."

N-907
Anchorage Connector

Completed with grade 8 nut & lock washer
 Forged steel, heat treated
 100% proof loaded to 3600 lbs / 16 kN
 Min. Breaking load : 5000 lbs / 23 kN
 Net weight : 21.3 oz. / 604 g

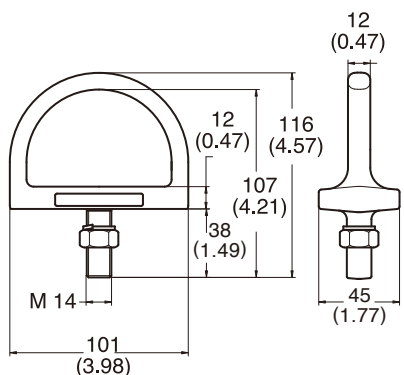

mm (inch)

Zinc Plated

**N-481
N-481R
Roof Anchor-reusable**

Net weight : 39.1 oz. / 1108 g

Art. No.	Color
N-481	Zinc plated
N-481R	Red Powder Coated

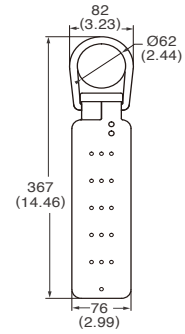

mm (inch)

**N-485
Swivel Roof Anchor Bracket**

Net weight : 39.2 oz. / 1120 g

Patent Pending

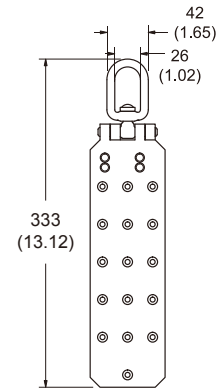

mm (inch)

Zinc Plated

**N-5072R
Roof Anchor Bracket**

Net weight : 39.5 oz. / 1120 g

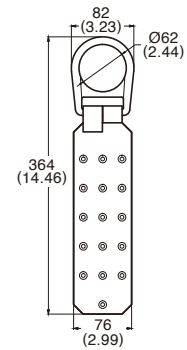

mm (inch)

Red Powder Coated

**N-5072F
Roof Anchor Bracket**

Net weight : 39.5 oz. / 1120 g

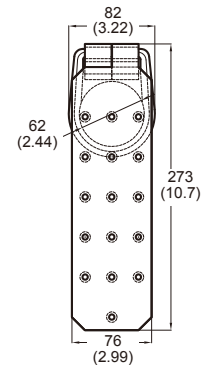

For Flat Surface mm (inch)

Zinc Plated

**N-480
Roof Anchor-disposable**

Net weight : 12.6 oz. / 357 g



Zinc Plated

**N-4805
Roof Anchor**

Net weight : 12.5 oz. / 335 g



Zinc Plated

For Flat Surface

**N-350 / N-3501 / N-3502
Anchorage Connector**

Stainless steel, SUS 304

Min. Breaking load : 5000 lbs / 23 kN

Net weight : 12.9 oz. / 366 g

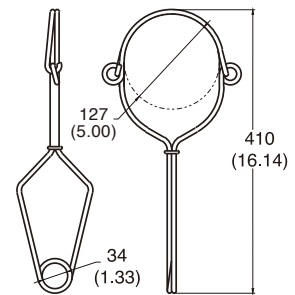

mm (inch)

Polished

**N-459
Steel Plate**

Net weight : 9.5 oz. / 271 g

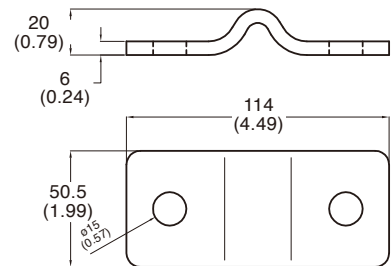

mm (inch)

Zinc Plated

N-5372
Rescue Hauler Pulley-2 way
Auto Locking

Stamping aluminum alloy
 Rope size : 11 mm
 Working load limit : 250 kg
 Net weight : 55.6 oz. / 1588 g

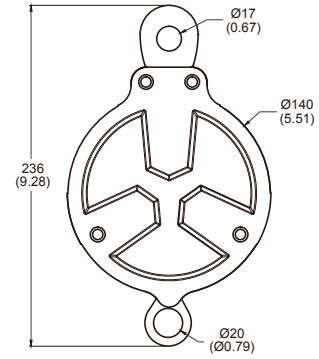

mm (inch)

Anodized

N-5331
Big Mobile Double Pulley

Stamping aluminum alloy
 Rope size : Maximum to 13 mm
 Min. Breaking load : 50 kN
 Net weight : 18.9 oz. / 539g

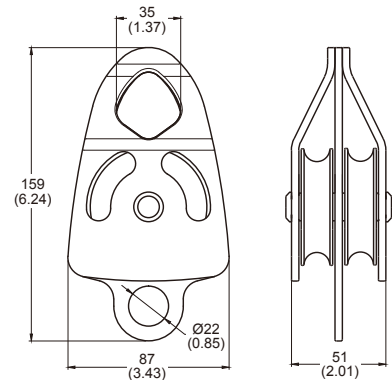

mm (inch)

Anodized

N-5331B
Big Mobile Double Pulley

With Ball Bearing
 With Stainless Sheave
 Stamping aluminum alloy
 Rope size : Maximum to 13 mm
 Min. Breaking load : 50 kN
 Net weight : 29.4 oz. / 834 g

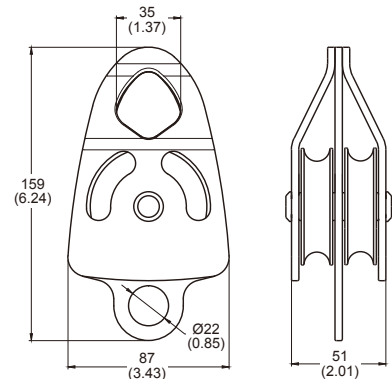

mm (inch)

Anodized

New

**N-6901
Cable Glider**

Stainless Steel
Net weight : 8.5 oz. / 241 g

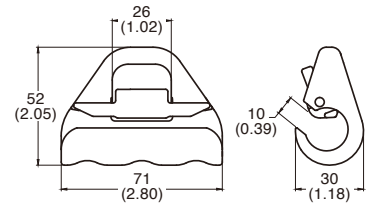

New

Polished

mm (inch)

**N-908
Roof Ring Anchor**

Steel, heat treated
Net weight : 34.71 oz. / 984 g

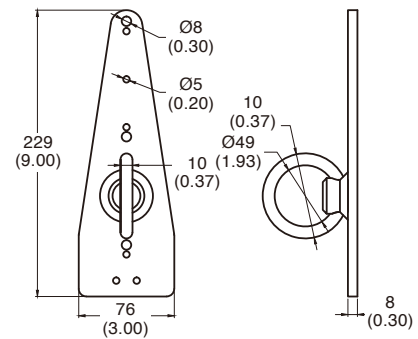

New

Zinc Plated

mm (inch)

**N-5340
Tyrolean Pulleys**

Stamping aluminum alloy
Rope size : Maximum to 13 mm
Min. Breaking load : 24 kN
Net weight : 8.6 oz. / 245 g

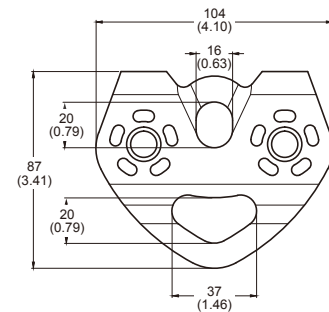
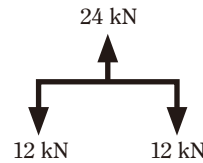

Anodized

mm (inch)

**N-5340B
Tyrolean Pulleys**

With Ball Bearing
With Stainless Sheave
Stamping aluminum alloy
Rope size : Maximum to 13 mm
Min. Breaking load : 24 kN
Net weight : 12.63 oz. / 358 g

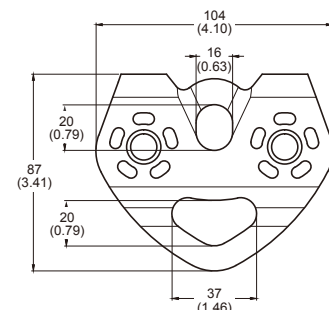
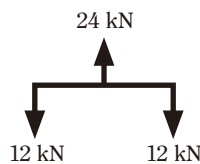

New

Anodized

mm (inch)

**N-5320
Fixed Pulley**

Stamping aluminum alloy
 Rope size : Maximum to 12 mm
 Min. breaking load : 20 kN
 Net weight : 3.1 oz. / 88 g

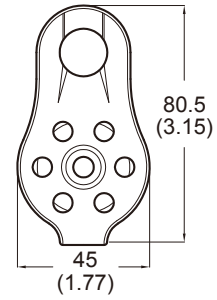

Anodized

mm (inch)

**N-5322
Mobile Pulley**

Stamping aluminum alloy
 Rope size : Maximum to 12 mm
 Min. breaking load : 20 kN
 Net weight : 4.1 oz. / 117 g

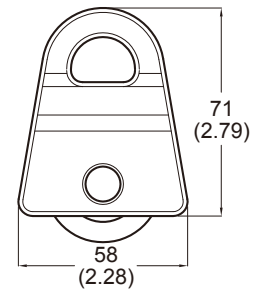

Anodized

mm (inch)

**N-5330
Mobile Pulley**

Stamping aluminum alloy
 Rope size : Maximum to 16 mm
 Min. breaking load : 30 kN
 Net weight : 9.6 oz. / 272 g

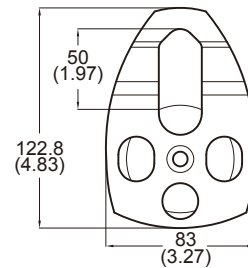

Anodized

mm (inch)

**N-5332
Mobile Double Pulley**

Stamping aluminum alloy
 Rope size : Maximum to 16 mm
 Min. breaking load : 30 kN
 Net weight : 16.8 oz. / 476 g

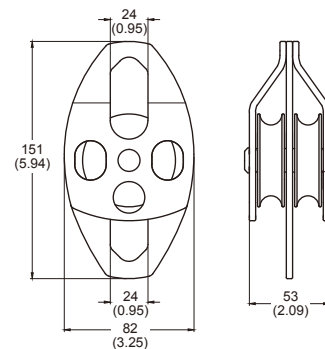

Anodized

mm (inch)

N-5300
Handled Ascender - Right Hand

Stamping aluminum alloy
Rope size : 9 mm to 12mm
● Meets : EN 567
Net weight : 6.9 oz. / 196 g

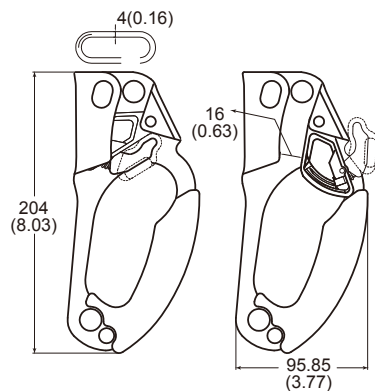

mm (inch)

Anodized

N-5302
Handled Ascender - Left Hand

Stamping aluminum alloy
Rope size : 9 mm to 12mm
● Meets : EN 567
Net weight : 6.9 oz. / 196 g

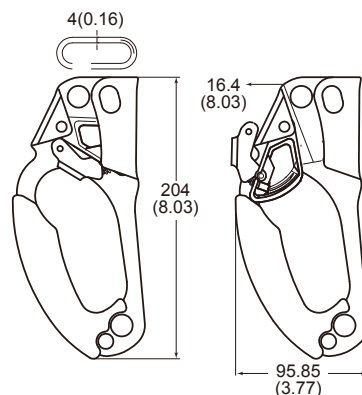

mm (inch)

Anodized

N-5306
Chest Ascender

Stamping aluminum alloy
Rope size : 9 mm to 12mm
● Meets : EN 567
Net weight : 5.8 oz. / 165 g

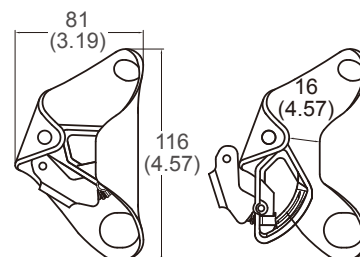

mm (inch)

Anodized

N-5350
Swivel

Forged aluminum alloy
Min. breaking load : 6000 lbs / 30 kN
Net weight : 5.6 oz. / 158 g



N-5350B

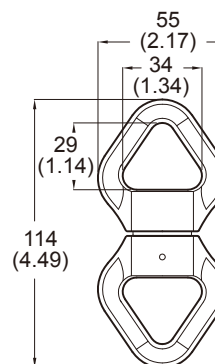

mm (inch)

Anodized

N-5350B
Swivel With Ball Bearing

Forged aluminum alloy
Min. Breaking load : 6000 lbs / 30kN
Net weight : 5.7 oz. / 163 g

**N-5310
Belay Tube**

Forged aluminum alloy
Rope size : 8 mm to 11 mm
Net weight : 2.0 oz. / 58 g

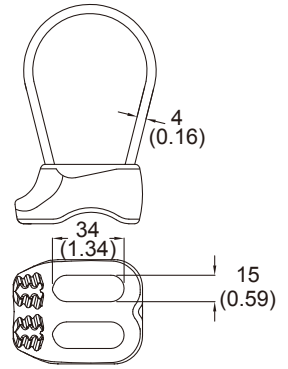

mm (inch)

Anodized

**N-5312
Belay Tube**

Forged aluminum alloy
Rope size : 8 mm to 11 mm
Net weight : 1.9 oz. / 53 g

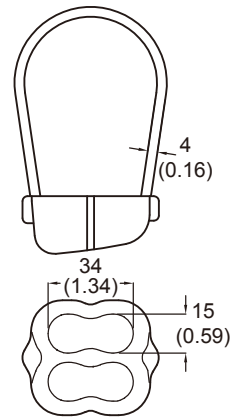

mm (inch)

Anodized

**N-2301-CP
Aluminum Carabiner**

Aluminum alloy
Min. Breaking load : 1800lbs / 8kN
Net weight : 1.02 oz. / 24 g

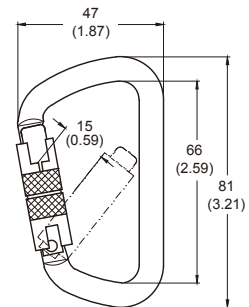

mm (inch)

Anodized

**N-220
Forged Accessory Hook**

Aluminum alloy
Min. breaking load : 5kN
Net weight : 0.7 oz. / 20 g

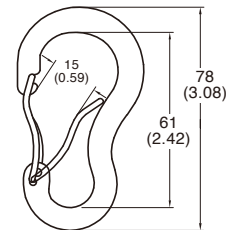

mm (inch)

Anodized

**N-5380
Rigging Plate**

Forged aluminum alloy
Min. breaking load : 35 kN
Net weight : 2.3 oz. / 65 g

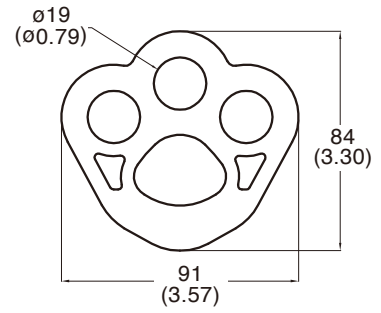

Anodized

mm (inch)

**N-5381
Rigging Plate**

Forged aluminum alloy
Min. breaking load : 35 kN
Net weight : 7.7 oz. / 220 g

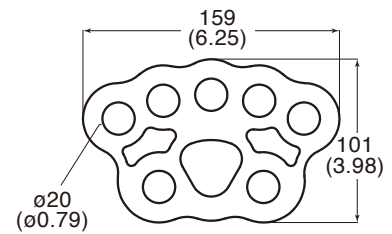

Anodized

mm (inch)

**N-5382
Rigging Plate**

Forged aluminum alloy
Min. breaking load : 45 kN
Net weight : 16.1 oz. / 460 g

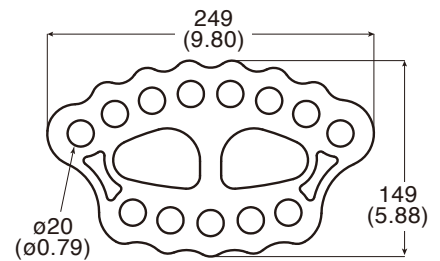

Anodized

mm (inch)

N-505
Figure 8 Descender

Forged aluminum alloy
For Rope : 3 / 8 " - 5 / 8 " (9 - 16 mm)
Min. Breaking load : 7500 lbs / 35 kN
Net weight : 4.1 oz. / 116 g

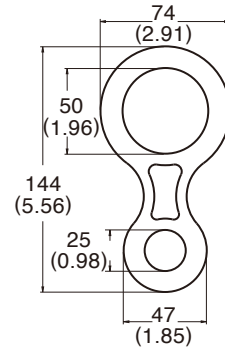

Anodized

mm (inch)

N-5052
Figure 8 Descender

Forged aluminum alloy
For Rope : 3 / 8 " - 5 / 8 " (9 - 16 mm)
Min. Breaking load : 5500 lbs / 25 kN
Net weight : 3.5 oz. / 100 g

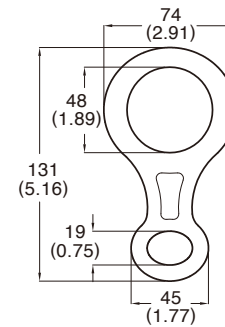

Anodized

mm (inch)

N-506
Big Figure 8 Descender

Forged aluminum alloy
For Rope : 3 / 8 " - 5 / 8 " (9 - 16 mm)
Min. breaking load : 9000 lbs / 40 kN
Net weight : 9.5 oz. / 270 g

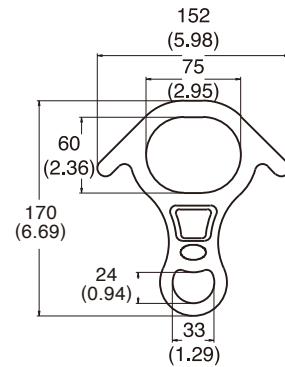

Anodized

mm (inch)

N-4506
Big Figure 8 Descender

Steel
For Rope : 3 / 8 " - 5 / 8 " (9 - 16 mm)
Min. breaking load : 11000 lbs / 50 kN
Net weight : 24.2 oz. / 691 g

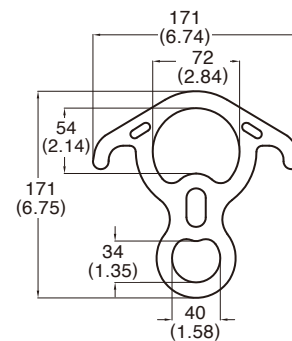

Zinc Plated

mm (inch)

S-7786-16
Rigging Screw Jaw and Stud

Stainless steel, SUS 316
 For wire rope : 8mm (5 / 16")
 Net weight : 32.0 oz. / 908 g

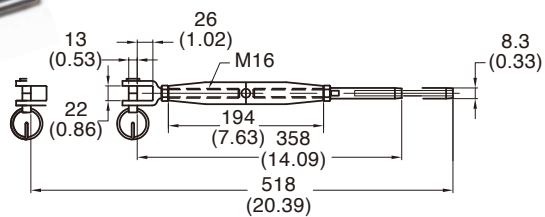

mm (inch)

Polished

S-7789-16
Rigging Screw Stud and Stud

Stainless steel, SUS 316
 For wire rope : 8mm (5 / 16")
 Net weight : 30.0 oz. / 850 g

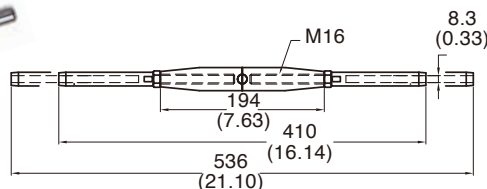

mm (inch)

Polished

S-7801-16
Swage Stud (right thread)

Stainless steel, SUS 316
 For wire rope : 8mm (5 / 16")
 Net weight : 9.0 oz. / 256 g

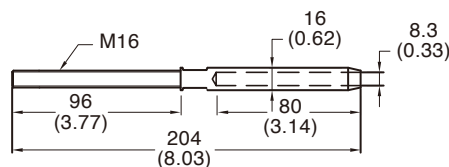

mm (inch)

Polished

S-7802-08
Eye Swage Stud

Stainless steel, SUS 316
 For wire rope : 8mm (5 / 16")
 Net weight : 3.4 oz. / 95 g

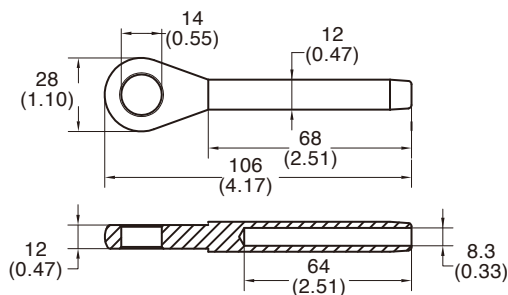

mm (inch)

Polished

S-7805-08
Jaw Swage Stud

Stainless steel, SUS 316
 For wire rope : 8mm (5 / 16")
 Net weight : 7.9 oz. / 223 g

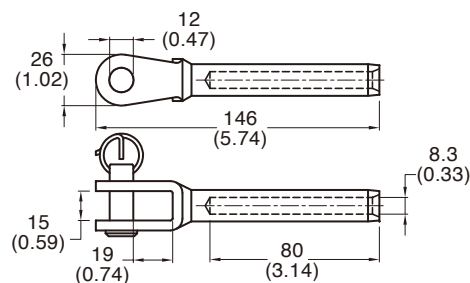

mm (inch)

Polished

N-704
Plastic shoulder pad

Colored : Black
Net weight : 1.8 oz. / 51 g

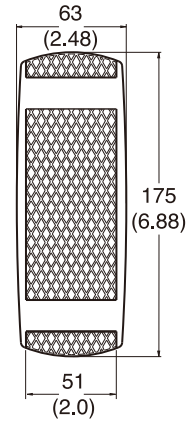

mm (inch)

N-703
Plastic Back pad

Net weight : 2.9 oz. / 83 g

Art. No.	Color
N-703.black	Black
N-703.red	Red
N-703.blue	Blue
N-703.yellow	Yellow
N-703.trans	Transparent

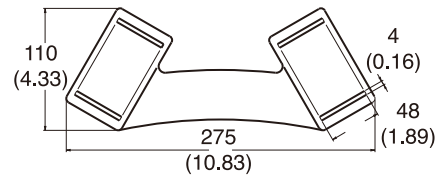

mm (inch)

N-701
Plastic Back pad

Net weight : 1.5 oz. / 44 g

Art. No.	Color
N-701.black	Black
N-701.red	Red
N-701.blue	Blue
N-701.yellow	Yellow

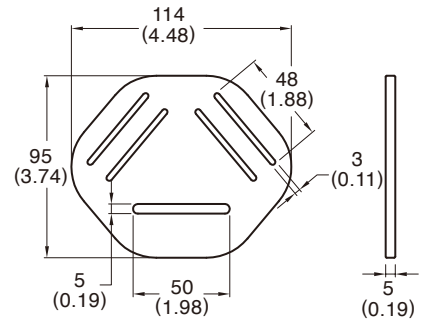

mm (inch)

N-Roller01 / N-Roller02 / N-Roller03 / N-Roller04 / N-Roller05 / N-Roller06 / N-Roller07
Plastic Roller

Art No.	A. Inner Dimension (Ø)	B. Overall Length (mm)
N-Roller01	10	25
N-Roller02	10	51
N-Roller03	12	42
N-Roller04	12	51
N-Roller05	12	65
N-Roller06	12	75
N-Roller07	15	49

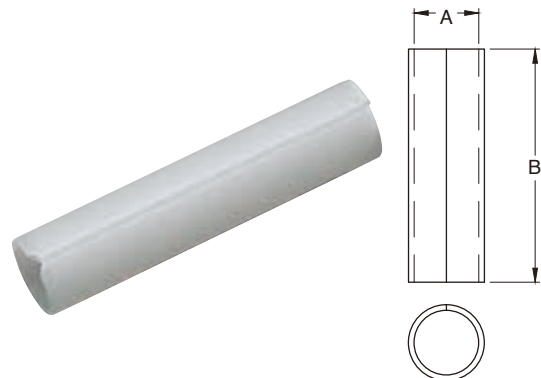

**N-710
Plastic Back pad**

Net weight : 0.80 oz. / 22 g

Art. No.	Color
N-710.black	Black
N-710.red	Red
N-710.blue	Blue
N-710.yellow	Yellow

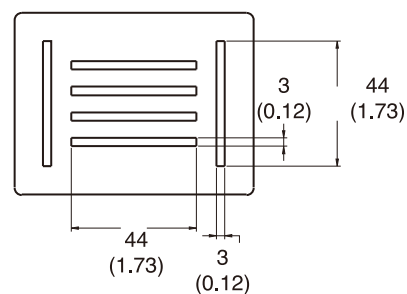

mm (inch)

**N-705
Plastic Pad Black**

Net weight : 0.4 oz. / 10 g

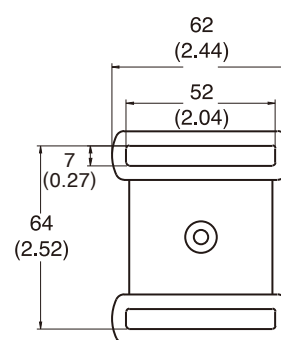

mm (inch)

**N-706
Plastic Keeper**

Net weight : 0.3 oz. / 9 g

Art. No.	Color
N-706.black	Black
N-706.red	Red
N-706.blue	Blue
N-706.yellow	Yellow

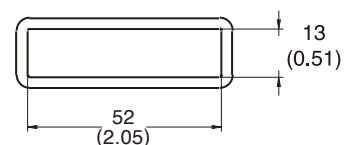

mm (inch)

**N-707
Plastic Back pad**

Net weight : 0.1 oz. / 3.5 g

Art. No.	Color
N-707.black	Black
N-707.red	Red
N-707.blue	Blue
N-707.yellow	Yellow

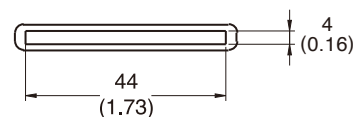

mm (inch)

**N-410
Plastic Thimble**

Net weight : 0.2 oz. / 7 g

Art. No.	Color
N-410.white	White
N-410.red	Red
N-410.blue	Blue
N-410.black	Black

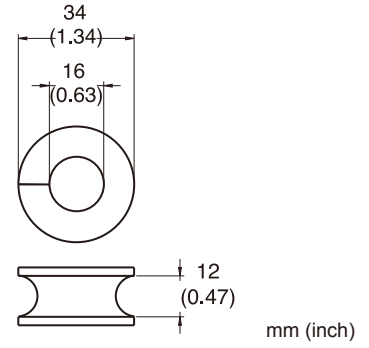

**N-4101
Brass Thimble**

Net weight : 0.21 oz. / 6 g

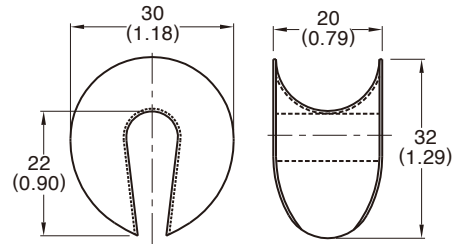

mm (inch)

**N-708
Plastic Protector Sleeve**

Net weight : 0.5 oz. / 15 g

Art. No.	Color
N-708.black	Black
N-708.red	Red
N-708.blue	Blue
N-708.yellow	Yellow

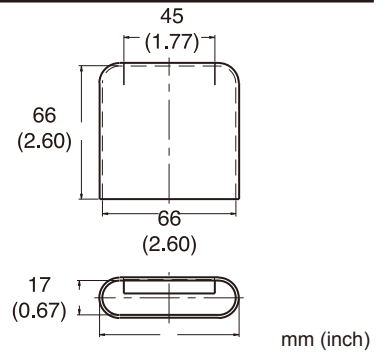

mm (inch)

**N-709
Plastic Protector Sleeve**

Net weight : 0.56 oz. / 16 g

Art. No.	Color
N-709.black	Black
N-709.red	Red
N-709.blue	Blue
N-709.yellow	Yellow

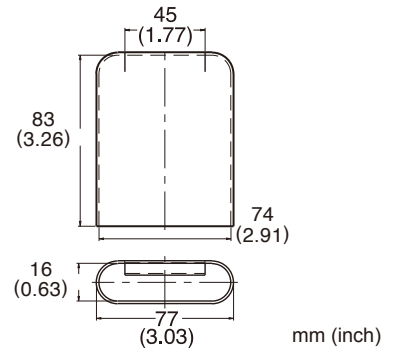

mm (inch)

**N-482
Double Lockout Jaw**

Net weight : 4.1 oz. / 117 g

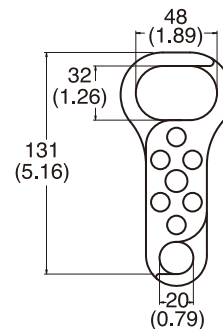

mm (inch)

Red Painted.

N-252GM-CP
Geomet Carabiner
3600 LBS gate strength

Steel Carabiner
 Alloy steel, heat treated
 100% proof loaded to 3600 lbs / 16kN
 Min. Breaking load : 5000 lbs / 23 Kn
 Meets :
 ● ANSI Z359.12-2019
 ● CSA Z259.12-16
 ● EN 362 : 2004
 Net weight : 8.96 oz. / 254 g
Geomet

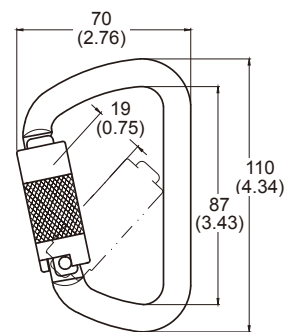

mm (inch)

N-248GL
Lifting Carabiner

Alloy steel, heat treated
 Net weight : 10.7 oz. / 303 g.
 Working Load Limit 2500 lbs
 Safety Factor 4 : 1
 For Material Handling

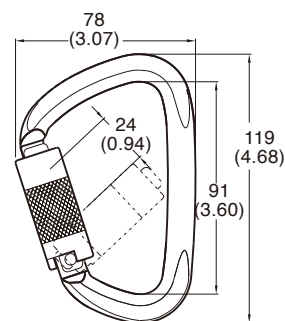

mm (inch)

New

Zinc Plated

N-483-ZN
O Ring

Forged steel, heat treated
 100% proof loaded to 3600 lbs / 16 kN
 Min. Breaking load : 5000 lbs / 23 kN
 Meets :
 ● ANSI Z359.12-2019
 ● CSA Z259.12-16
 ● Net weight : 5.2 oz. / 148 g



500 Hours Salt Spray

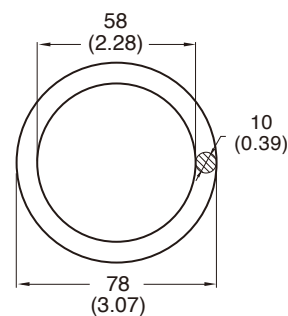

mm (inch)

New

Zinc Nickel

7350-08
Quick Link

Steel
 Net weight : 2.82 oz. / 80g

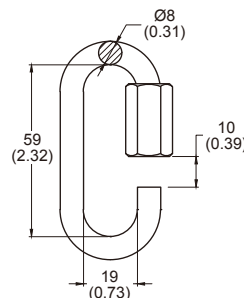

mm (inch)

Zinc Plated

**7355-08
Delta Link**

Steel
Net weight : 3 oz. / 85g

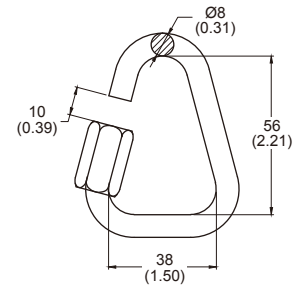

Zinc Plated

mm (inch)

**N-980
Anchor Point**

Material	Art No.	Net Weight	Ø
Steel	N-980-10	1.9 oz./55 g	10
	N-980-12	2.0 oz./58 g	12
Stainless Steel	N-980-S-10	1.8 oz./50 g	10
	N-980-S-12	1.9 oz./53 g	12

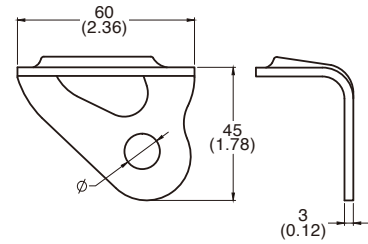

New

Anodized

mm (inch)

INDEX

Item No.	Page	Item No.	Page	Item No.	Page	Item No.	Page	Item No.	Page	Item No.	Page		
N-220	122	N-3035 / 0	11	N-4013	36	N-425	46	N-489	34	N-533	70	N-651B	110
N-2301-CP	122	N-3036	14	N-4014	36	N-426	46	N-4910	43	N-5330	120	N-660	111
N-244-O-S	78	N-3039	12	N-4016	36	N-427	46	N-4911	43	N-5331	118	N-668	109
N-244G	82	N-3040	12	N-402	31	N-428	36	N-492	25	N-5331B	118	N-670	111
N-245G	84	N-3040-1	13	N-402-S	75	N-429	32	N-492-BT	26	N-5332	120	N-6901	119
N-246G	85	N-3041	13	N-4021L	29	N-430	28	N-493	25	N-5340	119	N-701	126
N-247G-CP	87	N-3049	14	N-402W	31	N-430-S	74	N-493-BT	25	N-5340B	119	N-703	126
N-248G	86	N-3056	12	N-403	26	N-431	28	N-4940-BZP	43	N-5350	121	N-704	126
N-248GL	129	N-3058	13	N-403-S	75	N-431-S	76	N-4941	44	N-5350B	121	N-705	127
N-250G	82	N-3059	13	N-403XL	26	N-432	28	N-500	60	N-5372	118	N-706	127
N-250GK	82	N-306	10	N-403L	26	N-432A-S	75	N-501	60	N-5380	123	N-707	127
N-251G	84	N-314-MX	17	N-404	31	N-432-S	75	N-501110	60	N-5381	123	N-708	128
N-252-S	78	N-315	10	N-404R	31	N-433	41	N-501110X	61	N-5382	123	N-709	128
N-252G	83	N-3155	14	N-405	28	N-433L	41	N-50130	60	N-540	64	N-710	127
N-252GK	83	N-315X	10	N-4052	29	N-434	37	N-5015	61	N-5407	66	N-903	115
N-252GM-CP	129	N-3161	14	N-4053	24	N-435	38	N-5015/0	61	N-5407B	66	N-904	115
N-254G	85	N-3167	11	N-406	32	N-4355	46	N-5018	61	N-5416	64	N-904-S	74
N-256-S	78	N-3167 / 0	11	N-407	30	N-436	40	N-5019	66	N-5439	69	N-905	115
N-256G	83	N-325 / 0	17	N-407L	29	N-437	23	N-502	59	N-5719	67	N-907	115
N-258G-CP	87	N-326	17	N-407R	30	N-438	47	N-5020	66	N-5720	67	N-908	119
N-259G-CP	88	N-331	59	N-408	30	N-439	48	N-503	62	N-5721	67	N-980	130
N-261G	86	N-339	59	N-408R	30	N-439X	48	N-5032	62	N-5722	67	N-DE001	51
N-2615G	86	N-350	117	N-409	20	N-440	48	N-5035	62	N-5740	68	N-DE002	51
N-263G-CP	87	N-3501	117	N-410	128	N-441	48	N-5035 / 0	62	N-5741	68	N-DE005	54
N-265G-CP	88	N-3502	117	N-4101	128	N-442	35	N-504	59	N-5742	68	N-DE006	54
N-267G	85	N-351	113	N-411	45	N-443	44	N-505	124	N-5748	68	N-DE007	53
N-268G	84	N-352	113	N-412	43	N-445	27	N-5052	124	N-5860	73	N-DE009	53
N-268G-S	78	N-353	113	N-413	40	N-445L	27	N-506	124	N-5861	73	N-DE244-0	50
N-270	94	N-354	113	N-4135	40	N-448	42	N-507	65	N-5862	73	N-DE300	50
N-271	91	N-355	114	N-413X	40	N-448-S	77	N-5072F	116	N-5867	73	N-DE301	50
N-272	93	N-356	114	N-414	20	N-449	32	N-5072R	116	N-5868	71	N-DE360	50
N-273	94	N-357	114	N-414-S	76	N-4501	38	N-508	69	N-5868T	71	N-DE403	51
N-274	93	N-358	114	N-414R	20	N-4502	39	N-509	69	N-5869	72	N-DE403B	51
N-275	94	N-3591-S	74	N-414X	20	N-4506	124	N-511	69	N-5869T	71	N-DE415	52
N-2750	96	N-360	17	N-415	21	N-451	39	N-512	65	N-5870A	72	N-DE415B	52
N-276	93	N-3610	7	N-415-S	76	N-452	41	N-51428	70	N-5871	72	N-DE420	54
N-277	95	N-3610-S	79	N-415R	21	N-452L	41	N-51445	70	N-5877	71	N-DE4207	55
N-278	95	N-3615	8	N-415X	21	N-453	33	N-51460	70	N-602	108	N-DE422	55
N-281	91	N-3615-S	79	N-416	19	N-455	23	N-518	64	N-602-12	108	N-DE448	55
N-2817	29	N-3616	8	N-416L	19	N-459	117	N-519	64	N-604	109	N-DE452	55
N-282	92	N-3616-S	79	N-416L-R	19	N-460	24	N-5203	65	N-606AP	108	N-DE460	52
N-283	92	N-3617	8	N-416R	19	N-461	24	N-5204	65	N-608	111	N-DE460B	52
N-284	92	N-3618	8	N-417	22	N-469	24	N-5212	70	N-610	105	N-DE483	54
N-2852	96	N-3620T	16	N-418	21	N-475	32	N-5246	58	N-610LY	105	N-DE518	53
N-2852G	101	N-3625T	16	N-419	22	N-476	23	N-5248	58	N-616	106	N-DE529	53
N-2853G	101	N-3625T/0	16	N-419R	22	N-476R	23	N-5261	57	N-617	106	N-RCT27337	9
N-2854	96	N-3630T	15	N-420	37	N-477	22	N-5265	58	N-618	107	N-Roller01	126
N-2854G	101	N-3633T	15	N-420-S	76	N-478	25	N-5265 / 0	58	N-619	107	N-Roller02	126
N-2855	97	N-3633T/0	15	N-4201	37	N-479	47	N-5268	57	N-619T	107	N-Roller03	126
N-2855G	102	N-3658	9	N-4203	38	N-479-S	72	N-5271T	57	N-620	109	N-Roller04	126
N-2857	97	N-3660	9	N-4206	37	N-4793	47	N-5275T	57	N-621	109	N-Roller05	126
N-2857G	102	N-3680	16	N-4207	39	N-4797	47	N-528	63	N-622	109	N-Roller06	126
N-2857 / 0	97	N-3710	7	N-421	38	N-480	117	N-528A	63	N-623	109	N-Roller07	126
N-2857 / 0G	102	N-3810	7	N-421-S	77	N-4805	117	N-529	63	N-630	105	S-7786-16	125
N-2859	98	N-3810X	7	N-422	34	N-481	116	N-529A	63	N-630LY	105	S-7789-16	125
N-2859G	103	N-3830T	15	N-422-S	77	N-481R	116	N-5300	121	N-636	106	S-7801-16	125
N-2868G	103	N-400	45	N-4224	34	N-482	128	N-5302	121	N-637	106	S-7802-08	125
N-2817	29	N-400 / S	45	N-4226	34	N-483	33	N-5306	121	N-638	107	S-7805-08	125
N-287	95	N-4001	45	N-423	42	N-483-ZN	129	N-5310	122	N-639	108	7350-08	129
N-3032	10	N-401	35	N-423-S	77	N-485	116	N-5312	122	N-650	110	7355-08	130
N-3033	12	N-4011	35	N-4237	42	N-486	33	N-5320	120	N-650B	110		
N-3035	11	N-4012	35	N-424	42	N-487	33	N-5322	120	N-651	110		



YOKE INDUSTRIAL CORP.

#39, 33rd Road, Taichung Industrial Park,

Taichung 407, TAIWAN

Tel : +886-4-2350-8088

Fax : +886-4-2350-1001

E-mail : info@mail.yoke.net

[http : // www.yoke.net](http://www.yoke.net)



An ISO 9001 Certified Company

YOKE®

2020

Safety is our first priority™



Safety Components For Fall Protection